



HEALEY SURGEONS

301 270 8811

Fax: 301 357 8478

Email: healeysurgeons@aol.com

Website:

www.healeysurgeons.com

INTRODUCING HEALEY SURGEONS:

Healey Surgeons specializes in providing new and used parts for the "Big Healeys". Our new parts inventory is one of the most comprehensive in the US offering 1500 selections. The staff, with over 50 years of experience in servicing and restoring Austin Healeys, would be able to help you in selecting what is needed for your project.

RETURNS & REFUND:

For a full refund, please return part(s) within 4 weeks and in a condition that you would have liked to receive it. A copy of the invoice is needed, otherwise, a 15% restocking charge might be assessed. No returns will be accepted after 6 months. Used parts returns are subject to a 50% restocking charge because of the time we spent to remove it from "donor" cars.

WARRANTY:

All goods are backed by the manufacturer's warranty and subject to their terms and conditions. A copy of the invoice must accompany your warranty claim. A replacement part or a full refund will be issued after the manufacturer has evaluated the part in question.

HOURS:

Monday-Friday, 9:00-6:00 Eastern standard time

FOR TECHNICAL ASSISTANCE:

Check out the website's Tech Section, or call during our office hours, or send an e mail to the address above.

Note: *due to fluctuations caused by foreign exchange, these prices can change throughout the year. Please feel free to call for any updates.*

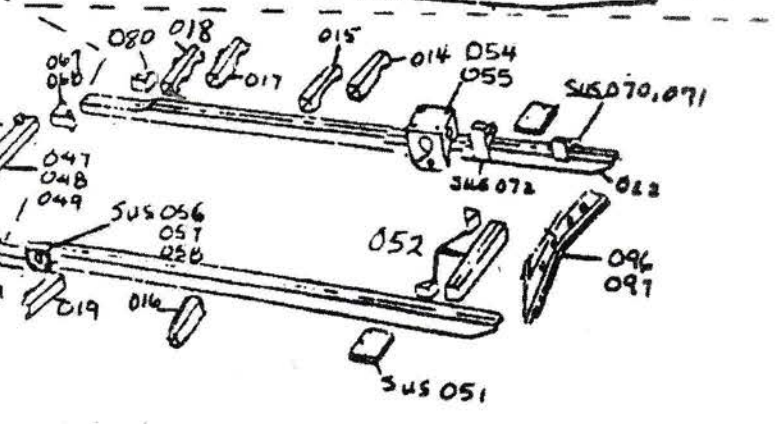
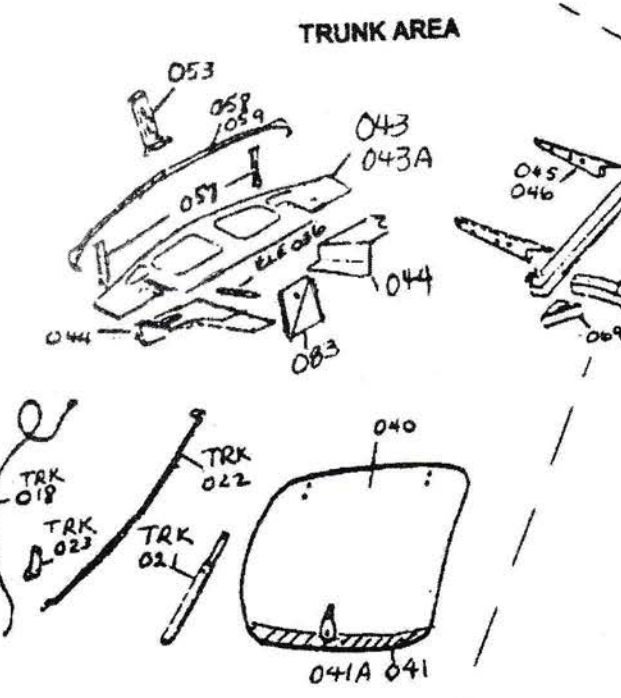
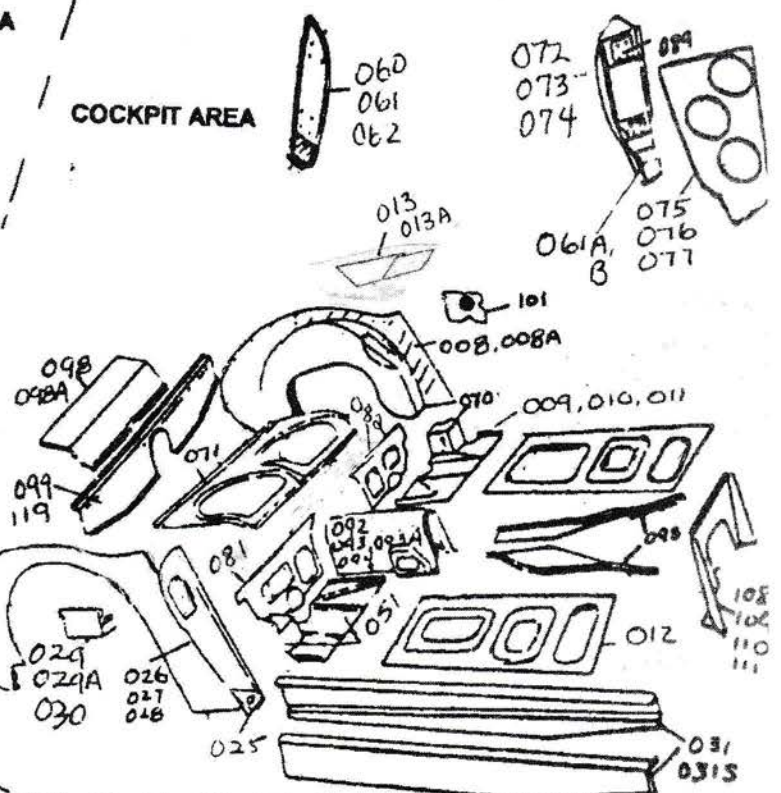
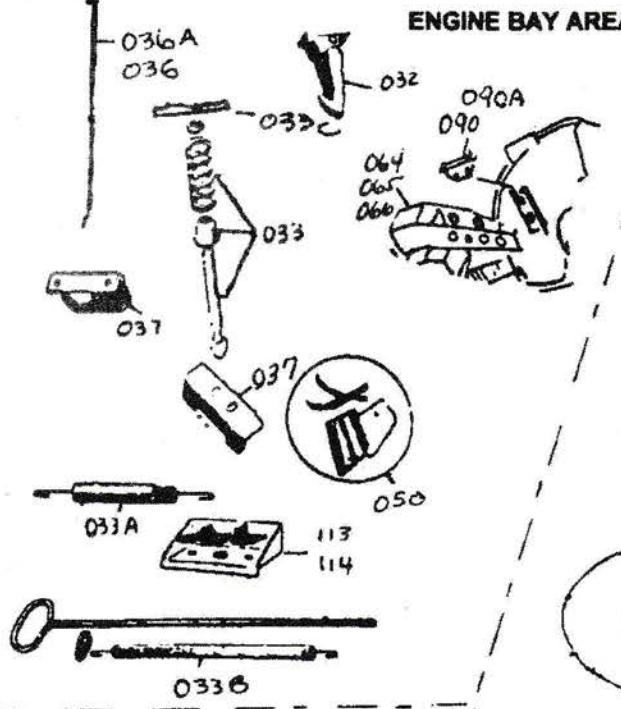
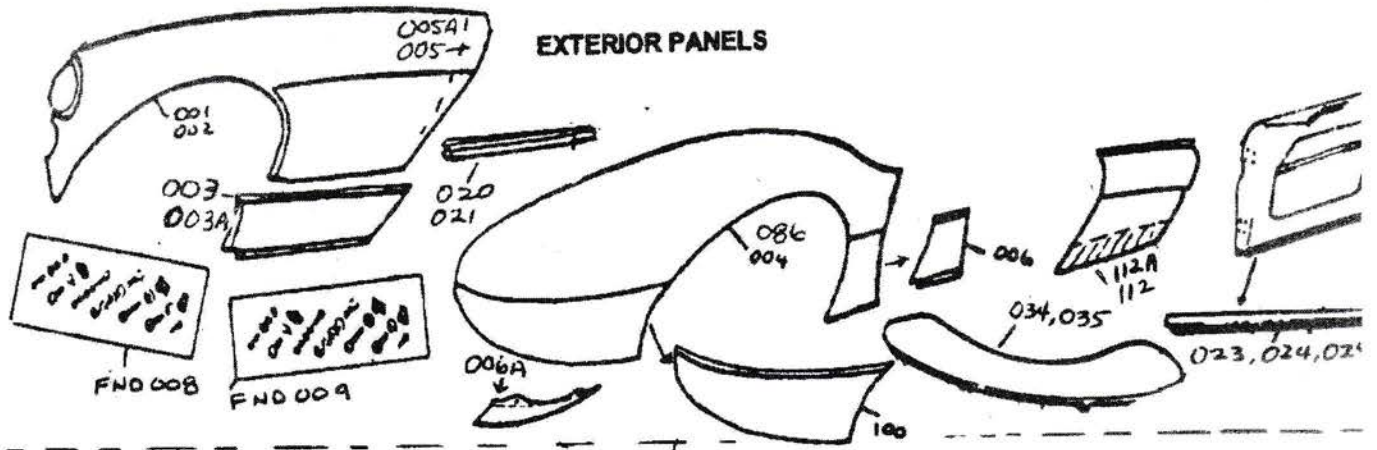

(301) 270-8811

BODY & STRUCTURAL

When ordering, please specify left (driver) or right (passenger) side.

EXTERIOR PANELS

BDY-034	FRONT BUMPER SPLASH PAN (ALUMINUM)	BN1-BN2	125.00
BDY-035	FRONT BUMPER SPLASH PAN (STEEL)	BN4-BJ8	100.00

FENDERS

BDY-005	FRONT FENDER BRACE	BN1-BT7	45.00
BDY-005A	FRONT FENDER BRACE	BJ 7-BJ8	45.00
BDY-003A	FRONT FENDER PATCH PANEL	BN1-BN2	250.00
BDY-003	FRONT FENDER PATCH PANEL	BN4-BJ8	250.00

BDY-006	REAR FENDER PATCH PANEL (DOG LEG)	BN1-BJ8	125.00
BDY-006A	REAR FENDER PATCH PANEL LOWER LIP	BN1-BJ8	50.00
BDY-100	REAR FENDER REAR QUARTER PATCH	BN1-BJ8	250.00

DOORS

BDY-112A	DOOR SKIN LOWER REPAIR PANEL	BN1-BN2	105.00
BDY-112	DOOR SKIN LOWER REPAIR PANEL	BN4-BJ8	105.00
BDY-023	DOOR REPAIR PANEL (BOTTOM)	BN1-BN2	75.00
BDY-024	DOOR REPAIR PANEL (BOTTOM)	BN4-BT7	85.00
BDY-024A	DOOR REPAIR PANEL (BOTTOM)	BJ7-BJ8	85.00

ROCKER PANELS

BDY-020	OUTER SILL (ROCKER PANEL)	BN1-BN2	60.00
BDY-021	OUTER SILL (ROCKER PANEL)	BN4-BJ8	60.00

Aluminum panels, fenders, shrouds, shroud repair panels, main frames are special order items. Deliveries take 4-6 weeks, please call for price.

ENGINE BAY AREA

BDY-050	WHEEL ARCH SPLASH PANEL SET	BN4-BJ8	110.00
BDY-022	SWAY BAR BRKT MOUNT PLATE	BN1-BJ8	15.00
BDY-102	CHASSIS TO SHROUD BRACE	BN4-BJ8	18.00
BDY-052	FRONT FRAME CROSS MEMBER	BN1-BJ8	140.00

BDY-096	SHOCK TOWER CROSS MEMBER	BN1-BN2	120.00
BDY-097	SHOCK TOWER CROSS MEMBER	BN4-BJ8	190.00

BDY-064	FIREWALL REINFORCE. BRACE	BN1-BN2	110.00
BDY-065	FIREWALL REINFORCE. BRACE	BN4-BT7	200.00
BDY-066	FIREWALL REINFORCE. BRACE	BJ7-BJ8	200.00

SHROUD & HOOD

BDY-090A	SHROUD MOUNTING BRACKET 4 PIECES	BN1-BN2	28.00
BDY-090	SHROUD MOUNTING BRACKET 4 PIECES	BN4-BJ8	30.00
BDY-091	SAFETY CATCH BRACKET (SHROUD)	BN4-BJ8	22.00

BDY-032	HOOD SAFETY CATCH	BN1-BJ8	16.00
BDY-033	HOOD LOCK STRIKER PIN & SPRING	BN1-BJ8	36.00
BDY-033C	HOOK LOCK BRACKET	BN1-BJ8	32.00
BDY-033A	HOOD LOCK RELEASE SPRING	BN4-BJ8	8.35
BDY-033B	HOOD RELEASE ANTI RATTLE SPRING	BN4-BJ8	4.00

BDY-036A	HOOD PROP ROD	BN1-BN2	40.00
BDY-036	HOOD PROP ROD	BN4-BJ8	40.00
BDY-037	HOOD PROP ROD BRACKET (SHROUD)	BN4-BJ8	14.00

** BJ8 PHASE II, WITH RADIUS ARM BOX

COCKPIT AREA

BDY-103	MAIN FRAME TOP/BOTTOM 4' REP. SECT	BN1-BJ8	85.00
BDY-104	CONVERTIBLE TOP FRAME MOUNT PANL	WHL ARCH	110.00
BDY-088	SQUARE CAGED NUT	BJ8	2.20
BDY-031	HEAVY DUTY SILLS (2 PARTS)	BN1-BJ8	180.00

OUTRIGGERS

BDY-014	FRONT OUTRIGGER (LH)	BN1-BJ7	140.00
BDY-015	FRONT OUTRIGGER (LH)	BJ8	140.00
BDY-016	FRONT OUTRIGGER (RH)	BN1-BJ8	140.00

BDY-017	REAR OUTRIGGR,GUSSET (LH)	BN1-BJ7	160.00
BDY-018	REAR OUTRIGGR,GUSSET (LH)	BJ8	160.00
BDY-019	REAR OUTRIGGR,GUSSET (RH)	BN1-BJ8	160.00
BDY-080	REAR OUTRIGGR LEAF SPRING HNGR BRKT	BN1-BJ8	45.00

DOOR HINGE AND STRIKER PANELS

BDY-060	DOOR HINGE PILLAR	BN1-BN2	115.00
BDY-061	DOOR HINGE PILLAR	BN4-BT7	115.00
BDY-062	DOOR HINGE PILLAR	BJ7-BJ8	115.00

BDY-089A	DOOR HINGE BLOCK (INSIDE PILLAR)	EARLY BN1	18.00
BDY-089	DOOR HINGE BLOCK (INSIDE PILLAR)	BN1-BJ8	18.00
BDY-089B	DOOR HINGE BLOCK (INSIDE DOOR)	BN1-BJ8	20.00

BDY-072	DOOR HINGE PILLAR ASSEMBLY	BN1-BN2	220.00
BDY-073	DOOR HINGE PILLAR ASSEMBLY	BN4-BT7	220.00
BDY-074	DOOR HINGE PILLAR ASSEMBLY	BJ7-BJ8	220.00

BDY-075	DOOR HINGE PILLAR BRACE	BN1-BN2	90.00
BDY-076	DOOR HINGE PILLAR BRACE	BN4-BT7	90.00
BDY-077	DOOR HINGE PILLAR BRACE	BJ7-BJ8	90.00

BDY-026	DOOR STRIKER PANEL	BN1-BN2	65.00
BDY-027	DOOR STRIKER PANEL	BN4-BT7	65.00
BDY-028	DOOR STRIKER PANEL	BJ7-BJ8	60.00
BDY-025	DOOR STRIKER PANEL LOWER GUSSET	BN1-BJ8	14.00
BDY-105	DOOR WINDLACING BRACKET SET		9.00

INNER FENDER PATCHES

BDY-008A	INNER REAR FENDER PATCH PANEL	BN1-BN2	110.00
BDY-008	INNER REAR FENDER PATCH PANEL	BN4-BJ8	110.00
BDY-084	REAR WHEEL ARCH PATCH PANEL	BJ7-BJ8	45.00

FLOOR SECTIONS & RADIUS ARM BOX REPAIR PANELS

BDY-013A	TOE BOARD	BN1-BN2	78.00
BDY-013	TOE BOARD	BN4-BJ8	78.00
BDY-012	FLOOR BOARD	BN1-BJ8	78.00

BDY-095	TRANS TUNNEL FLOOR EDGE SET	CNTRSHFT	200.00
---------	-----------------------------	----------	--------

BDY-009	REAR FLOOR	BN1-BN2	50.00
BDY-063	REAR FLOOR	BN6-BN7	70.00
BDY-010	REAR FLOOR	BN4-BJ8	110.00
BDY-011	REAR FLOOR	BJ8**	120.00

BDY-070	RADIUS ARM BOX & GUSSET	BJ8**	70.00
BDY-101	RADIUS ARM PATCH (WHEEL ARCH)	BJ8**	70.00

DRIVESHAFT & TRANSMISSION SECTIONS

BDY-094	INTERMEDIATE DRIVESHAFT TUNNEL	BN19	80.00
BDY-092	DRIVESHAFT TUNNEL	BN1-BN2	100.00
BDY-093A	DRIVESHAFT TUNNEL	BN4	110.00
BDY-093	DRIVESHAFT TUNNEL & SEAT BELT ANCHOR	BT7-BJ8	130.00

BDY-108	TRANS TUNNEL-FIREWALL EXTENS. PNL	BN1	90.00
BDY-109	TRANS TUNNEL-FIREWALL EXTENS. PNL	BN2	90.00
BDY-110	TRANS TUNNEL-FIREWALL EXTENS. PNL	SDESHT	240.00
BDY-111	TRANS TUNNEL-FIREWALL EXTENS. PNL	CNTSHFT	150.00

BOOKS

COCKPIT AREA (CON'T)

REAR SEAT & REAR VERTICAL AREA

BDY-081	REAR SEAT HEEL BOARD	BN4-BJ8	100.00
BDY-082	REAR SEAT HEEL BOARD	BJ8**	100.00
BDY-071	REAR SEAT PANEL	BN4-BJ8	310.00
BDY-098	BATTERY HATCH COVER	BN1-BN2	160.00
BDY-098A	BATTERY HATCH COVER	BN6-BN7	160.00
BDY-099	FLOOR-HATCH VERTICAL PANEL	BN1-BN2	185.00
BDY-119	FLOOR-HATCH VERTICAL PANEL	BN6-BN7	200.00

BUMP BOXES

BDY-029	REAR WHEEL ARCH BUMP BOX	BN1	50.00
BDY-029A	REAR WHEEL ARCH BUMP BOX	BN2-BJ7	30.00
BDY-030	REAR WHEEL ARCH BUMP BOX	BJ8**	30.00

TRUNK AREA

BDY-040	TRUNK LID	BN4-BJ8	1650.00
BDY-041	TRUNK LID LOWER REPAIR SECTION	BN4-BJ8	105.00
TRK-021	TRUNK LID PROP MECHANISM	BN1-BN2	45.00
TRK-022	TRUNK LID PROP ROD	BN4-BJ8	40.00
TRK-023	TRUNK LID PROP ROD BRCKT (SHROUD)	BN4-BJ8	11.00
TRK-018	TRUNK LID LIMITER CABLE	BN4-BJ8	28.00
BDY-043A	TRUNK FLOOR	BN1-BN2	140.00
BDY-043	TRUNK FLOOR	BN4-BJ8	140.00
BDY-044	TRUNK FLOOR BOX SECTION (LH/RH)	BN1-BJ8	85.00

BDY-083	BATTERY CABLE PANEL	4 SEATER	50.00
---------	---------------------	----------	-------

BDY-047	REAR CHASSIS CROSS MEMBER	BN1-BN2	200.00
BDY-048	REAR CHASSIS CROSS MEMBER	BN4-BJ8	200.00
BDY-049	REAR CHASSIS CROSS MEMBER	BJ8**	200.00
BDY-067	RR CHASSIS CRSS MEMBR GUSSET (LH)	BN1-BJ7	35.00
BDY-068	RR CHASSIS CRSS MEMBR GUSSET (LH)	BJ8**	40.00
BDY-069	RR CHASSIS CRSS MEMBR GUSSET (RH)	BN1-BJ8	40.00

BDY-045	BUMPER OUTRIGGER	BN1-BN2	115.00
BDY-046	BUMPER OUTRIGGER	BN4-BJ8	110.00
BDY-056	BUMPER OUTRIGGER:SHROUD SUPPORT	BN1-BN2	10.00
BDY-057	BMPR OUTRIGR:SHRD SUPPORT (LH/RH)	BN4-BJ8	25.00

BDY-053	REAR SHROUD TO FLOOR CENTER BRACE	BN1-BJ8	60.00
BDY-058	REAR SHROUD BRACE & END BRACKET	BN1-BN2	120.00
BDY-059	REAR SHROUD BRACE & END BRACKET	BN4-BJ8	120.00

BUMPER

BMP-001A	TRIPLE PLATED FRONT BUMPER	BN1-BN2	650.00
BMP-001	FRONT BUMPER	BN4-BJ8	300.00
BMP-001P	TRIPLE PLATED FRONT BUMPER	BN4-BJ8	700.00
BMP-002A	TRIPLE PLATED REAR BUMPER	BN1-BN2	700.00
BMP-002	REAR BUMPER	BN4-BJ8	300.00
BMP-002P	TRIPLE PLATED REAR BUMPER	BN4-BJ8	700.00
BMP-020	BUMPER OVERRIDER /GUARD	BN1-BN2	90.00
BMP-021	BUMPER OVERRIDER/GUARD	BN4-BJ8	65.00
BMP=021P	TRIPLE PLATED OVERRIDER	BN4-BJ8	150.00
BMP-012	RALLYE STYLE BUMPER OVERRIDER	BN1-BJ8	75.00
BMP-022	BUMPER OVERRIDER GASKET	BN1-BJ8	0.55

BMP-006	FRONT BUMPER BRACKET (LH/RH)	BN1-BN2	50.00
BMP-008	FRONT BUMPER BRACKET (LH/RH)	BN4-BJ8	50.00
BMP-007	REAR BUMPER BRACKET (LH/RH)	BN1-BN2	45.00
BMP-009	REAR BUMPER BRACKET (LH/RH)	BN4-BJ8	45.00
BMP-013	RALLYE STYLE BRACKET	BN1-BN2	60.00
BMP-014	RALLYE STYLE BRACKET	BN4-BJ8	60.00

BMP-011	BUMPER SPACER WASHER	BN1-BJ8	6.00
BMP-010	CHROME CARRIAGE BOLT:REAR BUMPR	BN4-BJ8	4.00
BMP-005	REAR BUMPER GROMMET (PAIR)	BN1-BJ8	8.00

BOK-001	FACTORY SERVICE MANUAL	BN1-BN2	90.00
BOK-002	FACTORY SERVICE MANUAL	BN4-BJ8	90.00

BOK-016	OWNER'S HANDBOOK	BN1-BN2	38.00
BOK-017	OWNER'S HANDBOOK	BN4-BN6	38.00
BOK-018	OWNER'S HANDBOOK	BN7-BJ7	38.00
BOK-019	OWNER'S HANDBOOK	BJ8	38.00

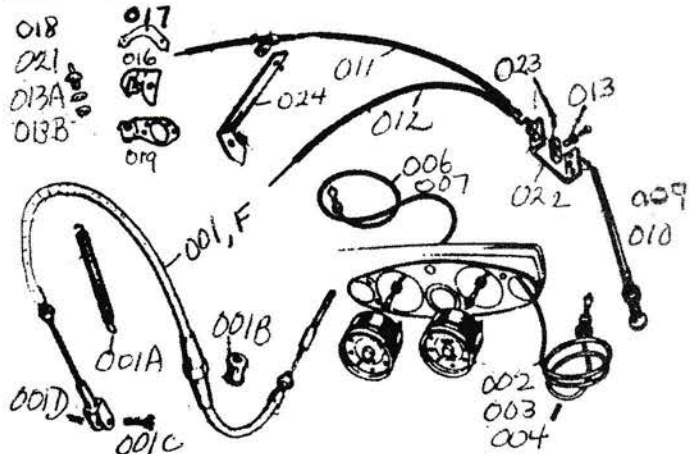

CABLES

HANDBRAKE CABLES

CBL-001F	HANDBRAKE CABLE	BN1-BN2	65.00
CBL-001	HANDBRAKE CABLE	BN4-BJ8	55.00
CBL-001A	HANDBRAKE CABLE SPRING	BN1-BJ8	7.00
CBL-001B	HANDBRAKE LINK ROD GROMMET	BN1-BJ8	5.00
CBL-001C	HANDBRAKE CABLE CLEVIS PIN	BN1-BJ8	1.00
CBL-001D	HANDBRAKE CABLE YOKE	BN1-BJ8	12.00
CBL-026	HANDBRAKE CABLE:CHASSIS BRACKET	BN1-BJ8	11.00

SPEEDOMETER & TACHOMETER CABLES

CBL-002	SPEEDOMETER CABLE	BN1-BN2	35.00
CBL-003	SPEEDOMETER CABLE (5'2")	SDSHFT	30.00
CBL-004	SPEEDOMETER CABLE (4'3")	CNTSHFT	28.00
CBL-006	TACHOMETER CABLE	BN1-BN2	25.00
CBL-007	TACHOMETER CABLE	BN4-BJ7	20.00

CHOKE CABLES & CONNECTORS

CBL-008	PRIMARY CHOKE CABLE WITH KNOB	BN1-BN2	40.00
CBL-009	PRIMARY CHOKE CABLE WITH KNOB	BN4-BJ7	30.00
CBL-010	PRIMARY CHOKE CABLE WITH KNOB	BJ7-BJ8	40.00
CBL-011	SECONDARY CHOKE CABLE (FRONT)	BJ7-BJ8	10.00
CBL-012	SECONDARY CHOKE CABLE (REAR)	BJ7-BJ8	10.00
CBL-022	CHOKE CABLE BRACKET (FIREWALL)	BJ7-BJ8	40.00
CBL-023	SPLITTER BLOCK FOR ABOVE	BJ7-BJ8	18.00
CBL-013	SPLITTER BLOCK CHKE CAB CONNECTER	BJ7-BJ8	3.00
CBL-024	CHOKE CABLE BRACKET (MANIFOLD)	BJ7-BJ8	14.00

CBL-018	CHOKE CABLE TRUNION	HS, H CARB	9.00
CBL-013	CHOKE CABLE TRUNION	HD CARBS	3.00
CBL-017	CHKE CAB ABUTM'T BRKT (AIR CLEANER)	BN1-BN2	20.00
CBL-019	CHKE CAB ABUTM'T BRKT (AIR CLEANER)	HD6 CARB	50.00
CBL-016	CHKE CAB ABUTM'T BRKT (AIR CLEANER)	HD8 CARB	28.00
CBL-021	CHOKE CABLE STOP	BN1-BN2	12.00
CBL-013B	CHOKE CABLE STOP	HD6 CARB	24.00
CBL-013A	CHOKE CABLE STOP	HD8 CARB	4.00
CBL-027	CHOKE CABLE STIRRUP	BN1-BN2	27.00

HEATER & COLD AIR CABLES

CBL-015	HEATER CABLE	BN4-BJ8	40.00
CBL-031	COLD AIR CABLE	BN1-BN2	65.00
CBL-014	COLD AIR CABLE	BN4-BJ8	45.00
CBL-025	COLD AIR CABLE CLAMP	BN1-BN2	12.00
CBL-020	CABLE CLAMP	BN4-BJ8	4.00

COOLING & HEATING

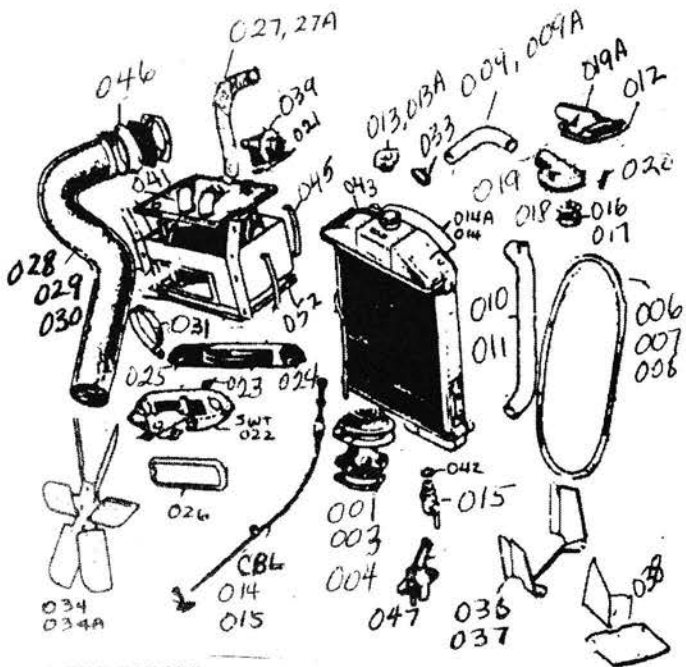

COL-020A	THERMOSTAT HOUSING STUD	BN1-BN2	4.00
----------	-------------------------	---------	------

HOSE CLAMPS			
COL-049	4" WIRE STYLE CLAMP	BN1-BJ8	8.00
COL-048	3-1/4" WIRE STYLE CLAMP	BN4-BJ8	6.00
COL-033	RADIATOR HOSE CLAMP (WIRE)	BN1-BJ8	2.70
COL-032	HEATER HOSE CLAMP (WIRE)	BN1-BJ8	2.20

AIR DUCTS & SECURING RINGS			
COL-028	4" COLD AIR DUCT	BN1-BJ9	85.00
COL-029	4" HEATER DUCT	BN4-BJ8	80.00
COL-030	3-1/4" HEATER DUCT	BN4-BJ8	70.00

COL-031	COLD AIR DUCT RING	BN1-BN2	12.00
COL-031	COLD AIR DUCT RING	BN4-BJ8	12.00
COL-046	AIR DUCT FLANGE	BN4-BJ8	13.50

COPPER PIPE, HEATER & ENGINE DRAIN TAPS			
COL-056	COPPER HEATER WATER RETURN PIPE	BN1-BN2	110.00
COL-057	COPPER HEATER WATER RETURN PIPE	LONGBRD	110.00
COL-058	COPPER HEATER WATER RETURN PIPE	BN4-BJ8	110.00

COL-040	HEATER CUT OFF VALVE	BN1-BN2	30.00
COL-047	HEATER CUT OFF VALVE	BN4-BJ8	75.00
COL-035	ENGINE BLOCK DRAIN TAP	BN4-BJ8	30.00

HEATER & CONTROLS			
COL-023A	HEATER KNOB	BN1-BN2	6.75
COL-023	HEATER KNOB	BN4-BJ8	6.00
COL-024	"PUSH" (HEATER) KNOB	BN4-BJ8	5.00
COL-025	"PULL" (COLD AIR) KNOB	BN4-BJ8	5.00
COL-022	HEATER CONTROL PANEL	BN4-BJ8	12.00
COL-026	HEATER CONTROL PANEL BEZEL	BJ8	58.00

HEATER CABLE : SEE CABLE SECTION, p. 4			
COL-041	HEATER VENT ELBOW	BN4-BJ8	10.00
COL-027	HEATER VENT DUCT	BN1-BJ8	17.00

COL-055	HEATER BLOWER CASING	BN4-BJ8	140.00
COL-054	HEATER BLOWER GROMMET	BN4-BJ8	4.00
COL-044	HEATER BOX BOTTOM	BN4-BJ8	40.00
COL-045A	HEATER BOX CLIP	BN1-BN2	15.00
COL-045	HEATER BOX CLIP	BN4-BJ8	3.00

OTHER HEATER BOX COMPONENTS ARE AVAILABLE, PLS CALL FOR PRICE

COL-039	HEATER BOX WATER VALVE	BN4-BJ8	40.00
COL-021	HEATER BOX WATER VALVE O RING	BN4-BJ8	0.75
COL-050	HEATER WATER VALVE CABLE	BN4-BJ8	12.00
COL-053	HEATER BOX "SMITH" ID PLATE	BN4-BJ8	6.50
COL-052	HEATER BOX "SMITH" ID BELL	BN1-BN2	8.50

CARPET

Normally, we only stock black carpet kits. All other colors are by special order, please allow 4-6 weeks for delivery. The kits are made like the original sets—no binding along the edges, "Austin" heel pad and felt padding.

OPTIONS:			
Jaguar quality carpet kit \$725. Original burlap backing \$600			
CPT-003	CARPET KIT	BN1-BN2	600.00
CPT-004	CARPET KIT	SDSHFT	580.00
CPT-005	CARPET KIT	CNTSFT	570.00
CPT-006	SPARE WHEEL BAG	BN6-BN7	125.00
CPT-011	CARPET CLIP ASSEMBLY	BN1-BJ8	1.30
CPT-012	"AUSTIN" HEEL PAD	BN1-BJ8	10.00
UPH-016	REAR DECK KIT & SPARE WHEEL BAG	BN1-BN2	380.00
UPH-037	REAR DECK KIT	BN6-BN7	100.00

WATER PUMPS			
COL-001	WATER PUMP	BN1-BN2	210.00
COL-060	WATER PUMP NUT	BN1-BN2	9.00
COL-003	WATER PUMP (3/8" PULLEY)	BN4-BJ8	110.00
COL-004	WATER PUMP (1/2" PULLEY)	BJ8	110.00
COL-003P	WATER PUMP (3/8") UK PRODUCT	BN4-BJ7	230.00
COL-004P	WATER PUMP (1/2") UK PRODUCT	BJ8	230.00
COL-005	WATER PUMP GASKET	BN4-BJ8	2.00
COL-051	WATER PUMP STUD	BN4-BJ8	2.00
BELTS & HOSES			
COL-006	FAN BELT	BN1-BN2	18.00
COL-007	FAN BELT (3/8" PULLEY)	BN4-BJ8	16.00
COL-008	FAN BELT (1/2" PULLEY)	BJ8	13.00
COL-009Ak	TOP RADIATOR HOSE (kevlar upgrade)	BN1-BN2	22.00
COL-009k	TOP RADIATOR HOSE (kevlar upgrade)	BN4-BJ8	22.00
COL-010K	BOTTOM RADIATOR HOSE (Kevlar upgrade)	BN1-BN2	32.00
COL-011K	BOTTOM RADIATOR HOSE (Kevlar upgrade)	BN4-BJ8	50.00
RADIATOR			
COL-062	RADIATOR (NEW)	BN4-BJ8	1400.00
COL-013A	RADIATOR CAP	BN1-BN2	5.00
COL-013	RADIATOR CAP	BN4-BJ8	7.00
COL-014A	RADIATOR FAN SHROUD	BN1-BN2	36.00
COL-014	RADIATOR FAN SHROUD	BN4-BJ8	25.00
COL-042	RADIATOR DRAIN TAP FIBER WASHER	BN1-BJ8	0.82
COL-015	RADIATOR DRAIN TAP	BN1-BJ8	26.00
COL-043	RADIATOR OVERFLOW TUBE	B14-BJ8	7.00
COL-038	AIR PANEL FOR RADIATOR	BN1-BN2	120.00
COL-036	AIR PANEL FOR RADIATOR (HORIZ GRILL)		100.00
COL-037	AIR PANEL FOR RADIATOR (VERT.GRILL)		100.00
FANS & THERMOSTATS			
COL-034A	FACTORY 6-BLADED RADIATOR FAN	BN1-BN2	150.00
COL-034	FACTORY 6-BLADED RADIATOR FAN	BN4-BJ8	150.00
COL-034AP	5 BLADED PLASTIC FAN	BN1-BN2	80.00
COL-034P	5 BLADED PLASTIC FAN	BN4-BJ8	80.00
COL-016	160 (SUMMER) THERMOSTAT	BN1-BJ8	8.00
COL-017	180 (WINTER) THERMOSTAT	BN1-BJ8	8.00
COL-012	THERMOSTAT GASKET	BN1-BN2	2.00
COL-018	THERMOSTAT GASKET	BN4-BJ8	3.00
COL-019A	THERMOSTAT HOUSING	BN1-BN2	80.00
COL-019	THERMOSTAT HOUSING	BN4-BJ8	20.00
COL-020	THERMOSTAT HOUSING STUD	BN4-BJ8	1.20

DOOR

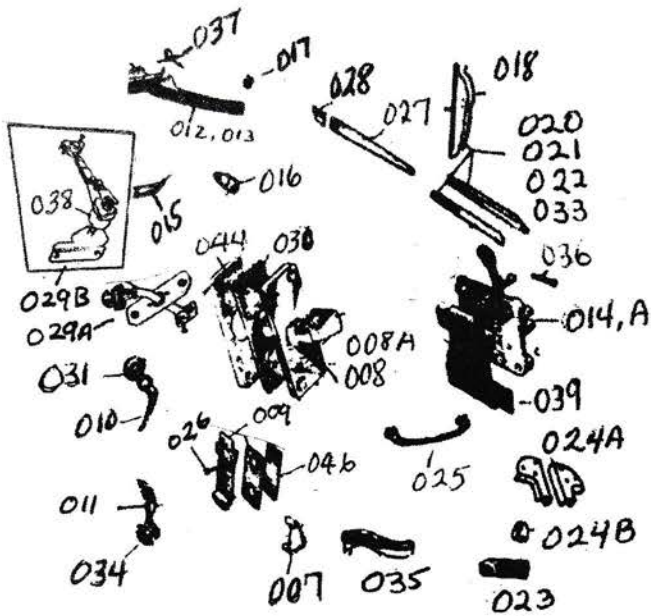

ELECTRIC

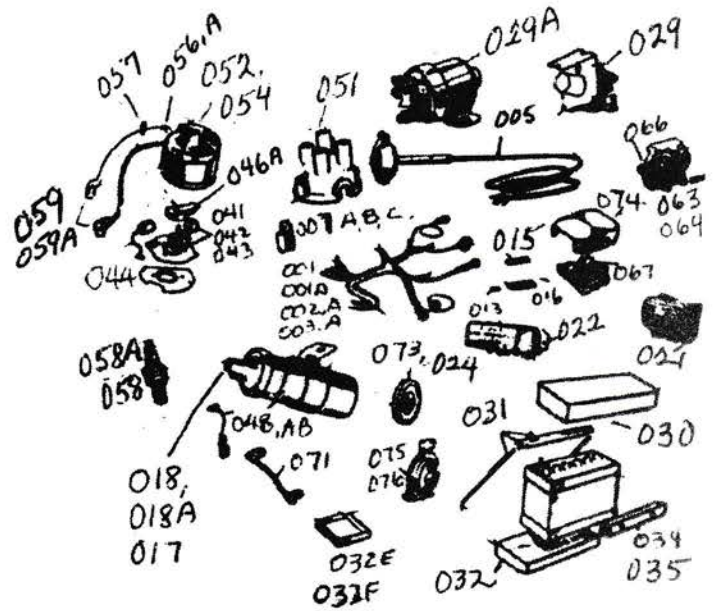

DOOR STRIKERS, LATCHES & LOCKS

DOR-008	DOOR STRIKER & PLATE	BN1-BT7	65.00
DOR-030	DOOR STRIKER SHIM	BN1-BT7	6.00
DOR-044	DOOR STRIKER TAPPED BACKING PLATE	BN1-BT7	15.00
DOR-009	DOOR STRIKER PLATE (LH/RH)	BJ7-BJ8	50.00
DOR-047	DOOR STRIKER SHIM	BJ7-BJ8	8.00
DOR-046	DOOR STRIKER TAPPED BACKING PLATE	BJ7-BJ8	13.00
DOR-007	DOOR LATCH CHROME PLATE	BN4-BT7	10.00
DOR-036	DOOR LATCH HANDLE	BN1-BN2	15.00
DOR-014	DOOR LATCH (LH/RH)	BN1-BN2	100.00
DOR-014A	DOOR LATCH (LH/RH)	BN4-BT7	75.00
DOR-050	DOOR LATCH (LH/RH)	BJ7-BJ8	180.00
DOR-039	DOOR LATCH HOUSING BRACKET (LH/RH)	BN1-BT7	35.00

INTERIOR & EXTERIOR DOOR HANDLES

DOR-036	INTERIOR DOOR KNOB	BN1-BN2	16.00
DOR-010	INTERIOR DOOR HANDLE	BN4-BT7	18.00
DOR-011	INTERIOR DOOR HANDLE	BJ7-BJ8	40.00
DOR-031	INTERIOR DOOR HANDLE ESCUTCHEON	BN4-BT7	19.00
DOR-034	INTERIOR DOOR HANDLE ESCUTCHEON	BJ7-BJ8	22.00
DOR-012	EXTERIOR LEVER DOOR HANDLE (LH/RH)	BN4-BT7	150.00
DOR-013	EXTERIOR LEVER DOOR HANDLE (LH/RH)	BJ7-BJ8	150.00
DOR-013A	EXTERIOR PUSH BOTTOM DOOR HANDLE	BJ8	180.00
DOR-037	LEVER DOOR HANDLE SPRING	BN4-BJ8	5.00
DOR-017	LEVER DOOR HANDLE BUMP	BN4-BJ8	1.10
DOR-015	LEVER DOOR HANDLE GASKET	BN4-BJ8	3.00
DOR-016	PUSH BUTTON DOOR HANDLE GASKET	BJ8	2.00

ALUMINUM DOOR TRIMS

DOR-019	ALUM DOOR TRIM SCREW SET (PER DOOR)	BN1-BJ8	3.00
DOR-020	ALUM DOOR TRIM SET (LH/RH)	BN1-BN2	140.00
DOR-033	ALUM DOOR TRIM SET (LH/RH)	LNGBRIDGE	140.00
DOR-021	ALUM DOOR TRIM SET (LH/RH)	BN4-BT7	180.00
DOR-022	ALUM DOOR TRIM SET (LH/RH)	BJ7-BJ8	180.00

DOOR SEALS & PIPINGS

DOR-018	DOOR PILLAR PIPING SET	BN1-BJ8	8.80
DOR-035	DOOR SEAL SET (SPECIFY COLOR) PER YD	BN1-BN2	16.00
DOR-040	DOOR SEAL SET	LNGBRIDGE	180.00
DOR-041	DOOR SEAL METAL TRACK SET	LNGBRIDGE	125.00
DOR-024C	DOOR SEAL FINISHER SET	LNGBRIDGE	75.00
DOR 023	DOOR SEAL	BN4-BJ8	95.00
DOR 023C	DOOR SEAL (BLACK ONLY)	BN4-BJ8	125.00
DOR-024A	DOOR SEAL FINISHER SET	BN4-BT7	15.00
DOR-024B	DOOR SEAL FINISHER SET	BJ7-BJ8	8.00

MISCELLANEOUS

DOR-025	DOOR OR TOP PULL HANDLE	BJ7-BJ8	18.00
DOR-026	DOOR HINGE SCREW	BN1-BJ8	0.75
DOR-027	DOOR TOP CHROME MOLDING (LH/RH)	BJ7-BJ8	180.00
DOR-028	DOOR-REAR SHROUD CHROME (LH/RH)	BJ7-BJ8	70.00
DOR-029A	DOOR CHECK ASSEMBLY	BN1-BN2	90.00
DOR-029B	DOOR CHECK ASSEMBLY (LH/RH)	BN4-BJ8	90.00

DOR-038	DOOR CHECK FRICTION DISK	BN4-BJ8	4.00
---------	--------------------------	---------	------

WIRING HARNESES, CONNECTORS & CLIPS

ELE-001	WIRING HARNESS, CLOTH COVERED	BN1	500.00
ELE-001A	WIRING HARNESS, CLOTH COVERED	BN2	500.00
ELE-002	WIRING HARNESS, CLOTH COVERED	BN4	500.00
ELE-002A	WIRING HARNESS, CLOTH COVERED	BN6-BJ7	550.00
ELE-003	WIRING HARNESS CLOTH COVERED	BJ8-I	550.00
ELE-003A	WIRING HARNESS CLOTH COVERED	BJ8-II	550.00
ELE-009	WIRING HARNESS DECAL	BN1-BJ8	1.65
ELE-012	HEADLIGHT HARNESS (PAIR)	BN1-BJ8I	30.00
ELE-004A	OVERDRIVE HARNESS	BN1	60.00
ELE-004B	OVERDRIVE HARNESS	BN2-BJ7	50.00
ELE-004C	OVERDRIVE HARNESS	BJ8	50.00
ELE-005	STATOR TUBE WIRING HARNESS	BN1-BJ8	55.00

ELE-008	HEADLIGHT HARNESS CLIP	BN1-BJ8	1.50
ELE-007A	WIRING HARNESS CLIP (SMALL 1/4")	BN1-BJ8	1.00
ELE-007B	WIRING HARNESS CLIP (MEDIUM 3/8")	BN1-BJ8	1.00
ELE-007C	WIRING HARNESS CLIP (LARGE 1/2")	BN1-BJ8	1.00
ELE-007	WIRING HARNESS CLIP (FIREWALL)	BN1-BJ8	1.50

OTHER SIZES ALSO AVAILABLE IN 1/16" INCREMENTS

ELE-013	BULLET CONNECTOR	BN1-BJ8	0.50
ELE-015	SINGLE WIRE CONNECTOR	BN1-BJ8	0.75
ELE-016	DOUBLE WIRE CONNECTOR	BN1-BJ8	0.75

STARTER, GENERATOR COMPONENTS, VOLT. REG.

ELE-021	VOLTAGE REGULATOR (TESTED & ADJ)	BN1-BJ7	95.00
ELE-022	VOLTAGE REGULATOR (TESTED & ADJ)	BJ8	95.00

ELE-073	GENERATOR PULLEY	BN1-BN2	80.00
ELE-024	GENERATOR PULLEY (1/2")	BJ8	100.00
ELE-025	GENERATOR BRUSH SET	BN1-BN6	19.00
ELE-026	GENERATOR BRUSH SET	BN7-BJ7	16.00
ELE-027	GENERATOR BRUSH SET	BJ8	16.00

ELE-028	STARTER BRUSH SET	BN1-BJ8	14.00
ELE-029A	PUSH BUTTON STARTER SOLENOID	BN1-BJ8	45.00
ELE-029	STARTER SOLENOID	BN1-BJ8	22.00

BATTERY & ACCESSORIES

ELE-030	BATTERY COVER	BN4-BJ8	12.00
ELE-031	BATTERY TIE DOWN BAR & HOOKS	BN4-BJ8	35.00
ELE-032E	BATTERY TRAY SET	2 SEATER	40.00
ELE-032	BATTERY TRAY	4-SEATER	50.00
ELE-036	BATTERY TRAY SUPPORT BRACKET	4-SEATER	55.00
ELE-034	BATTERY WOOD SUPPORT	BN4-BT7	20.00
ELE-035	BATTERY WOOD SUPPORT	BJ7-BJ8	30.00
ELE-033	LUCAS BATTERY DECAL		4.00

ELECTRICS (CON'T)

IGNITION COMPONENTS

ELE-018	IGNITION COIL (LUCAS PUSH ON ENDS)	BN1-BJ8	50.00
ELE-018A	IGNITION COIL (SCREW ON ENDS)	BN1-BJ8	50.00
ELE018AL	IGNITION COIL LUCAS (SCREW ON ENDS)	BN1-BJ8	55.00
ELE-017	SPORTS COIL	BN1-BJ8	45.00

ELE-041	POINTS	BN1-BN2	18.00
ELE-042A	POINTS	BN4-BJ7	8.00
ELE-043	POINTS	BJ7*-BJ8	8.00
ELE-044	CONDENSER UPGRADED	BN1-BJ8	9.00
ELE-045	ROTOR: UPGRADED	BN1-BN2	8.00
ELE-046	ROTOR: UPGRADED	BN4-BJ8	8.00
ELE-048A	DISTRIBUTOR TENSION LEAD WIRE	BN1-BN2	15.00
ELE-048	DISTRIBUTOR TENSION LEAD WIRE	BJ7*-BJ8	5.00
ELE-051	DISTRIBUTOR CAP	BN1-BN2	23.00
ELE-052	DISTRIBUTOR CAP	BN4-BJ7	45.00
ELE-054	DISTRIBUTOR CAP	BJ7*-BJ8	45.00
ELE-058A	SPARK PLUG	BN1-BN2	5.00
ELE-058	SPARK PLUG	BN4-BJ8	5.00
ELE-059A	IGNITION WIRE SET	BN1-BN2	29.00
ELE-059	IGNITION WIRE SET	BN4-BJ8	30.00
ELE-057	IGNITION WIRE O RING	BN4-BJ8	0.75
ELE-056A	IGNITION WIRE LABEL SET	BN1-BN2	3.75
ELE-056	IGNITION WIRE LABEL SET	BN4-BJ8	4.00

CABLES

ELE-050A	SWITCH TO GROUND CABLE	BN1-BN2	8.00
ELE-050	SWITCH TO GROUND CABLE	BN4-BJ8	10.00
ELE-049B	BATTERY (+) TO SWITCH CABLE	BN1-BN2	32.00
ELE-049A	BATTERY (+) TO SWITCH CABLE	BN6, BN7	13.00
ELE-049	BATTERY (+) TO SWITCH CABLE	4 SEATER	24.00
ELE-068A	BATTERY (-) TO SOLENOID CABLE	2 SEATER	40.00
ELE-068	BATTERY (-) TO SOLENOID CABLE	4 SEATER	75.00
ELE-069	SOLENOID TO STARTER CABLE	BN1-BJ8	18.00
ELE-071	ENGINE GROUND STRAP	BN1-BJ8	18.00
ELE-077	BATTERY CABLE GROMMET SET	4 SEATER	35.00

FUSES

ELE-063	35 AMP FUSE	BN1-BJ8	0.65
ELE-064	50 AMP FUSE	BN1-BJ8	0.65
ELE-066	FUSE BOX	BN1-BJ7	15.00
ELE-067	FUSE BOX	BJ8	11.00
ELE-074	FUSE BOX COVER	BJ8	5.50

MISCELLANEOUS

ELE-075	HORN (LOW NOTE)	BJ7-BJ8	37.00
ELE-076	HORN (HIGH NOTE)	BJ7-BJ8	37.00

*BJ7 engine 29F3563 onwards

FENDER

FND-001	FENDER SPEAR	BN1-BJ8	45.00
FND-002	FRONT FENDER BEADING	BN1-BJ8	60.00
FND-003	REAR FENDER BEADING	BN1-BJ8	70.00
FND-004A	UPPER FENDER WELT	BN1-BN2	0.83
FND-004	UPPER FENDER WELT	BN4-BJ8	0.83
FND-005A	LOWER FENDER WELT	BN1-BN2	1.10
FND-005	LOWER FENDER WELT	BN4-BJ8	1.10
FND-006	FENDER BOLT	BN1-BJ8	0.44
FND-007	FENDER SPEED NUT	BN1-BJ8	0.55
FND-008	FRONT FENDER KIT (FOR 1 FENDER)	BN1-BJ8	18.00
FND-009	REAR FENDER KIT (FOR 1 FENDER)	BN1-BJ8	18.00

FASTENER

FSN-001	TENAX STUD (BODY)	BN1-BJ8	2.50
FSN-001A	TENAX STUD (DASH)	BN1-BT7	2.50
FSN-001B	TENAX STUD (BACKREST)	BJ7	2.50
FSN-002	TENAX BUTTON	BN1-BJ8	4.50
FSN-003	LIFT THE DOT STUD	BN1-BJ8	1.50
FSN-004	LIFT THE DOT PLATE	BN1-BJ8	1.65
FSN-005	TURN BUTTON STUD	BN1-BT7	1.50
FSN-006	TURN BUTTON EYELET	BN1-BT7	1.00
FSN-007	TENAX/LIFT DOT STUD CLEAR WASHER	BN1-BJ8	0.22

EXHAUST

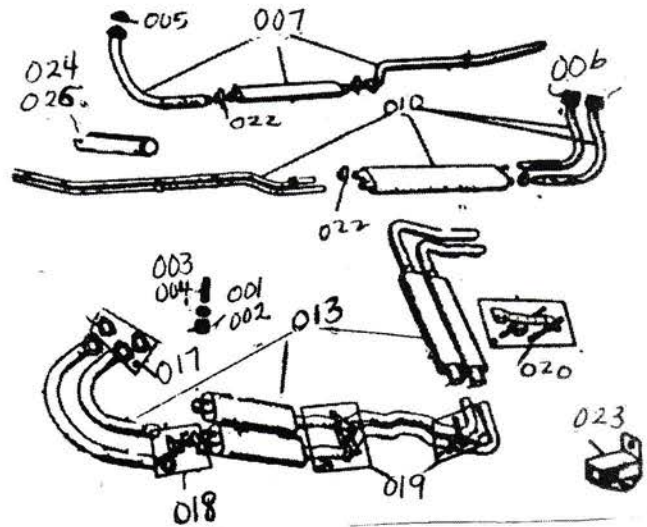

EXH-001	MANIFOLD TO HEAD BRASS NUT	BN1-BN2	2.00
EXH-002	MANIFOLD TO HEAD BRASS NUT	BN4-BJ8	0.75
EXH-003	HEADPIPE TO MANIFOLD STUD	BN1-BN2	1.65
EXH-004	HEADPIPE TO MANIFOLD STUD	BN4-BJ8	1.35
EXH-005	HEADPIPE GASKET	BN1-BN2	4.00
EXH-006	HEADPIPE GASKET	BN4-BJ8	8.00
EXH-016	EXHAUST HEADPIPE BRACKET	BN1-BN2	30.00
EXH-022	STAINLESS EXH CLAMPS (ORIGINAL STYLE)	BN1-BJ8	6.00
AVAILABLE IN 1.5", 1.75", 1.87" AND 2" SIZES. PLS. SPECIFY MODEL.			
EXH-023	EXHAUST RUBBER HANGER MOUNT	BN1-BJ8	6.50
EXH-030	EXHAUST HANGING STUD (FLOOR)	BN1-BJ8	1.50
EXH-007A	EXHAUST MOUNTING KIT	BN1-BN2	50.00
EXH-015	EXHAUST MOUNTING KIT	BN4-BJ7	60.00
EXH-018	FRONT MOUNTING KIT	BJ8	60.00
EXH-019	INTERMEDIATE MOUNTING KIT	BJ8	90.00
EXH-020	REAR MOUNTING KIT	BJ8	90.00
ALL CLAMPS ARE STAINLESS STEEL			

If you only need individual components, not a complete system. Please call for price.

EXH-007	MILD STEEL EXHAUST SYSTEM	BN1-BN2	570.00
EXH-007SS	STAINLESS STEEL EXHAUST SYSTEM	BN1-BN2	710.00
EXH-010	MILD STEEL EXHAUST SYSTEM	BN4-BJ7	750.00
EXH-010SS	STAINLESS STEEL EXHAUST SYSTEM	BN4-BJ7	850.00
EXH-013	MILD STEEL EXHAUST SYSTEM	BJ8	1400.00
EXH-013SS	STAINLESS STEEL EXHAUST SYSTEM	BJ8	1500.00

BELL STAINLESS EXHAUST SYSTEMS. MADE IN U.K.

VISIT OUR WEBSITE

WWW.HEALEYSURGEONS.COM

FOR
TECH TIPS

HEAD

VALVES & GUIDES

ENG-024	INTAKE GUIDE	BN1-BN2	5.00
ENG-028	INTAKE GUIDE	BN4-BJ8	4.00
ENG-025	EXHAUST GUIDE	BN1-BN2	5.00
ENG-029	EXHAUST GUIDE	BN4-BJ8	5.50

ENG-026	INTAKE VALVE	BN1-BJ8	10.50
ENG-023	EXHAUST VALVE	BN1-BN2	10.00
ENG-027	EXHAUST VALVE	BN4-BJ8	15.00
ENG-022	VALVE COLLET	BN1-BJ8	12.00
ENG-022A	VALVE COLLET CLIP	BN1-BJ8	1.10
ENG-021A	VALVE SPRING SET	BN1-BN2	55.00
ENG-021	VALVE SPRING SET	BN4-BJ8	55.00

ROCKERSHAFT

ENG-059	ROCKER SHAFT	BN1-BN2	40.00
ENG-060	ROCKER SHAFT	BN4-BJ8	45.00
ENG-061	ROCKER SHAFT BUSHING	BN1-BJ8	4.00
ENG-063	ROCKER SHAFT PEDESTAL OIL FEED	BN1-BN2	46.00
ENG-064	ROCKER SHAFT PEDESTAL OIL FEED	BN4-BJ8	46.00
ENG-057A	BOLT FOR ROCKER SHAFT PED OIL FEED	BN1-BN2	18.00
ENG-057	BOLT FOR ROCKER SHAFT PED. OIL FEED	BN4-BJ8	10.00
ENG-065	CRUSH WASHER FOR BOLT	BN1-BJ8	1.95
ENG-058A	OIL FEED PIPE	BN1-BN2	40.00
ENG-058	OIL FEED PIPE	BN4-BJ8	40.00

VALVE COVER

MIS-047	VALVE COVER DECAL:AUSTIN (RIVET)	BN4-BJ8	7.00
MIS-048	VALVE COVER DECAL: VALVE ADJ (RIVET)	BN4-BJ8	12.00
MIS-049	RIVETS FOR DECAL	BN4-BJ8	0.66
MIS-045	VALVE COVER DECAL:AUSTIN (STICK ON)	BJ8	10.00
MIS-046	VALVE COVER DECAL: VALVE ADJ (STICK ON)BJ8	BJ8	10.00

ENG-067A	STAINLESS VALVE COVER T SECTION	BN4-BJ8	75.00
ENG-067B	STAINLESS VALVE COVER BOLT	BN1-BN2	17.00
ENG-067	STAINLESS VALVE COVER BOLT	BN4-BJ8	30.00
ENG-071SS	STAINLESS VALVE COVER CUP WSHR SET	BN1-BJ8	15.00

ENG-068	VALVE COVER OIL FILLER CAP	BN4-BJ8	18.00
ENG-070	VALVE COVER RUBBER BUSH	BN1-BJ8	1.10
ENG-071	VALVE COVER CUP WASHER	BN1-BJ8	4.00

BOTTOM END

CRANKSHAFT

ENG-004	CRANKSHAFT PULLEY	BN1-BN2	260.00
ENG-005	CRANKSHAFT PULLEY (HARMONIC BALANCER)	BN1-BJ8	625.00
ENG-105	CRANKSHAFT PULLEY REPAIR SLEEVE	BN1-BJ8	45.00
ENG-008	CRANKSHAFT WOODRUFF KEY	BN1-BJ8	2.00
ENG-007	CRANKSHAFT NUT	BN1-BJ8	44.00
ENG-006	CRANKSHAFT NUT TAB WASHER	BN1-BJ8	5.00
ENG-001	CRANKSHAFT TIMING GEAR	BN1-BJ8	50.00

CAMSHAFT & TAPPET

ENG-030R	REGROUND CAMSHAFT	BN1-BJ8	250.00
\$200 CORE CHARGE, ADDITIONAL LOBE REPAIR \$15 EXTRA.			
ENG-002	CAMSHAFT TIMING GEAR	BN1-BN2	200.00
ENG-003	CAMSHAFT TIMING GEAR	BN4-BJ8	80.00
ENG-009	CAMSHAFT WOODRUFF KEY	BN1-BJ8	2.00
ENG-010	CAMSHAFT SPROCKET NUT	BN1-BJ8	7.00
ENG-011	CAMSHAFT SPROCKET TAB WASHER	BN1-BJ8	2.00
ENG-107	CAMSHAFT LOCATING THRUST PLATE	BN1-BJ8	20.00
ENG-014	TAPPET (CAM FOLLOWER, LIFTER)	BN1-BN2	12.00
ENG-015	TAPPET (CAM FOLLOWER, LIFTER)	BN4-BJ8	12.00

TIMING

ENG-016	TIMING CHAIN TENSIONER TAB WASHER	BN4-BJ8	1.37
ENG-017	TIMING CHAIN	BN1-BJ8	14.00
ENG-017NS	TIMING CHAIN (NON STRETCH)	BN4-BJ8	60.00
ENG-018	TIMING CHAIN TENSIONER	BN4-BJ8	14.00
ENG-138	TIMING CHAIN DAMPNER	BT7-BJ8	17.00
ENG-019	TIMING COVER SEAL	BN1-BN2	1.70
ENG-020	TIMING COVER SEAL	BN4-BJ8	7.00
ENG-114	TIMING COVER OVAL WASHER (SMALL)	BN4-BJ8	1.00
ENG-114A	TIMING COVER OVAL WASHER (LARGE)	BN4-BJ8	1.00

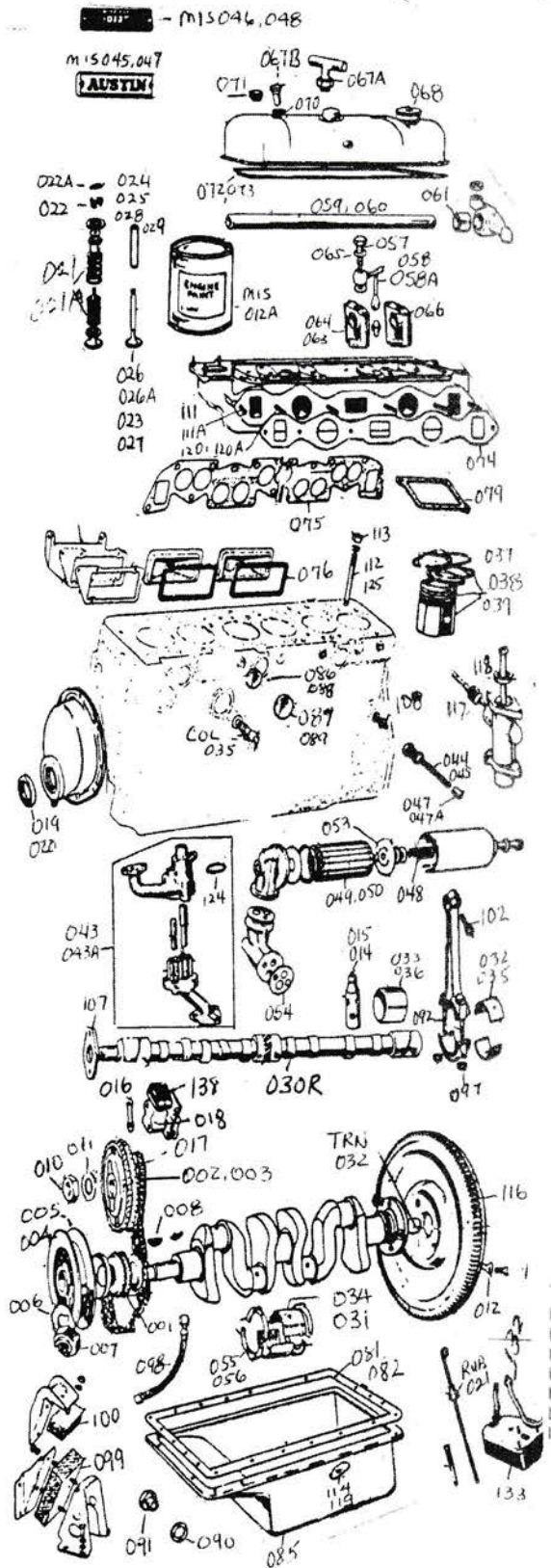

ENGINE (Cont.)

WHEN ORDERING PISTONS, BEARINGS & THRUST WASHERS, PLEASE SPECIFY SIZE: STD, .010, .020, .030 ETC. Limited quantities of AE parts are available, call for price.

BEARINGS & THRUST WASHERS

ENG-055	THRUST WASHER SET	BN1-BN2	30.70
ENG-056	THRUST WASHER SET	BN4-BJ8	12.00
ENG-031	MAIN BEARING SET	BN1-BN2	90.00
ENG-034	MAIN BEARING SET	BN4-BJ8	135.00
ENG-032	ROD BEARING SET	BN1-BN2	90.00
ENG-035	ROD BEARING SET	BN4-BJ8	135.00
ENG-033	CAM BEARING SET	BN1-BN2	85.00
ENG-036	CAM BEARING SET	BN4-BJ8	60.00

PISTONS

ENG-037	PISTON & RING SET	BN1-BN2	450.00
ENG-038	PISTON & RING SET(BUSH)	BN4-BN6	520.00
ENG-039	PISTON & RING SET	BT7-BJ8	470.00
ENG-041	PISTON-CONNECTING ROD BUSH SET	BN4-BJ8	17.00

OIL PUMPS, PRESSURE VALVES, SPRINGS

ENG-043A	OIL PUMP	BN1-BN2	600.00
ENG-043	OIL PUMP \$250	UPGRADED BN4-BJ8	400.00
ENG-133	OIL PUMP SUMP/STRAINER	BN1-BN2	130.00
ENG-132	OIL PUMP DELIVERY LINE	BN1-BN2	95.00
ENG-044	OIL PRESSURE RELEASE SPRING	BN1-BN2	3.00
ENG-045	OIL PRESSURE RELEASE SPRING	BN4-BJ8	3.58
ENG-047A	OIL PRESSURE RELEASE VALVE	BN1-BN2	6.00
ENG-047	OIL PRESSURE RELEASE VALVE	BN4-BJ8	13.00

OIL FILTERS

ENG-049	FELT OIL FILTER	BN1-BJ8	9.00
ENG-050	PAPER OIL FILTER	BN1-BJ8	8.00
ENG-101A	ZDDP OIL ADDITIVE	BN1-BJ8	15.00
ENG-054	OIL FILTER TO BLOCK GASKET	BN1-BJ8	1.20
ENG-051	OIL FILTER FELT BUSH	BN1-BJ8	1.20
ENG-052	OIL FILTER RUBBER BUSH	BN1-BJ8	1.50
ENG-053	OIL FILTER PRESSURE PLATE	BN1-BJ8	12.00

SUMP

ENG-091	SUMP DRAIN PLUG	BN1-BJ8	8.00
ENG-090	SUMP DRAIN PLUG COPPER WASHER	BN1-BJ8	2.50
ENG-119	SUMP BOLT OVAL WASHER	BN4-BJ8	0.83

GASKETS

ENG-131	HYLOMAR GASKET SEALANT (100g)		18.50
ENG-072	VALVE COVER GASKET	BN1-BN2	4.00
ENG-073	VALVE COVER GASKET	BN4-BJ8	10.00
ENG-074	MANIFOLD TO HEAD GASKET	BN1-BN2	6.00
ENG-075A	MANIFOLD GASKET (LONGBRIDGE)	2 PORT HD	16.30
ENG-075	MANIFOLD TO HEAD GASKET	BN4-BJ8	9.00
ENG-079A	INTAKE TO EXHAUST MANIFOLD GASKET	TRICARB	4.50
ENG-079	INTAKE TO EXHAUST MANIFOLD GASKET	BN4-BJ8	5.00

ENG-040A	TIMING COVER GASKET	BN1-BN2	3.00
ENG-040	TIMING COVER GASKET	BN4-BJ8	3.30
ENG-085	TAPPET COVER GASKET	BN1-BN2	7.00
ENG-076	CORK TAPPET COVER GASKET	BN4-BJ8	2.10
ENG-076A	PAPER TAPPET COVER GASKET	BN4-BJ8	1.80
ENG-081	SUMP (OIL PAN) GASKET	BN1-BN2	12.00
ENG-082	SUMP (OIL PAN) GASKET & WASHER	BN4-BJ8	12.00
ENG-077P	PAYEN HEAD GASKET ONLY (SPECIAL ORDER)		125.00
ENG-077	HEAD GASKET SET	BN1-BN2	100.00
ENG-077A	HEAD GASKET SET (2 PORT HEAD)	BN4	110.00
ENG-078	HEAD GASKET SET	BN4-BJ8	75.00
ENG-083	BOTTOM END (CONVERSION) GSKT SET	BN1-BN2	50.00
ENG-084	BOTTOM END (CONVERSION) GSKT SET	BN4-BJ8	60.00
ENG-128	REAR ENGINE PLATE GASKET	BN4-BJ8	10.00
ENG-136	REAR MAIN SEAL KIT	BN1-BN2	125.00
ENG-137	REAR MAIN SEAL KIT	BN4-BJ8	125.00
ENG-135	REAR MAIN SEAL	BN1-BJ8	12.00

ENG-098	OIL FLEX LINE	BN1-BJ8	20.00
ENG-108	METAL LINE FOR OIL FLEX LINE	BN1-BJ8	50.00
ENG-099	ENGINE MOUNT (SIDE)	BN1-BJ8	15.00
ENG-100	ENGINE MOUNT (TOP)	BN1-BJ8	8.00
ENG-093	GENERATOR/TAPPET COVER	BN4-BJ7	140.00
ENG-094	GENERATOR/TAPPET COVER	BJ8	140.00
ENG-080	TAPPET COVER COPPER WASHER	BN4-BJ8	0.95
ENG-013	WATER GALLEY BLANKING PLATE	BN1-BN2	45.00
ENG-118	DISTRIBUTOR SEAL	BN4-BJ7	7.00
ENG-134	SPEEDOMETER SEAL	BN1-BJ8	9.00
ENG-117	TACHOMETER SEAL	BN1-BJ7	6.00
ENG-116	STARTER RING GEAR	BN1-BJ8	45.00
MIS-012A	ENGINE PAINT (SPRAY CAN)	BN1-BJ8	30.00
ENG-106	TUBE FOR OIL DIP STICK	BN1-BN2	12.00
ENG-122	BREATHER PIPE	BN4-BJ8	25.00
ENG-123	BREATHER PIPE HOSE CLAMP	BN4-BJ8	3.50
ENG-086	FREEZE PLUG (CUP OR SUACER)	BN1-BJ8	1.75

NUTS & BOLTS

ENG-102	GUDGEON PIN BOLT	BN1-BN2	3.50
ENG-097A	CONNECTING ROD NUT	BN1-BN2	2.75
ENG-130	MANIFOLD TO HEAD YOLK WASHER	BN1-BN2	3.30
ENG-095	MANIFOLD TO HEAD BRASS NUT	BN1-BN2	4.00
ENG-111	MANIFOLD TO HEAD STUD (SHORT)	BN1-BN2	1.50
ENG-111A	MANIFOLD TO HEAD STUD (LONG)	BN1-BN2	1.50
ENG-113	HEAD NUT	BN1-BN2	3.50
ENG-112	HEAD STUD	BN1-BN2	8.00
ENG-092	CONNECTING ROD BOLT	BN4-BJ8	20.00
ENG-097	CONNECTING ROD NUT	BN4-BJ8	3.00
ENG-042	MAIN BEARING CAP NUT	BN4-BJ8	3.20
ENG-120A	MANIFOLD TO HEAD STUD	BN4	3.00
ENG-120	MANIFOLD TO HEAD STUD	BN4-BJ8	3.00
ENG-110	EXH. MANIFOLD TO HEAD STUD	BN4-BJ8	3.00
ENG-096	MANIFOLD TO HEAD BRASS NUT	BN4-BJ8	2.00
ENG-139	HEAD NUT	BN4-BJ8	2.25
ENG-125	HEAD STUD	BN4-BJ8	6.00
ENG-062	ROCKERSHAFT STUD (LONG)	BN4-BJ8	5.00
ENG-062A	ROCKERSHAFT STUD (COVER)	BN4-BJ8	4.75
ENG-062B	ROCKERSHAFT STUD (SHORT)	BN4-BJ8	3.30
ENG-115A	FLYWHEEL BOLT	BN1-BN2	8.00
ENG-115	FLYWHEEL BOLT	BN4-BJ8	3.00
ENG-115H	FLYWHEEL BOLT (HEAVY DUTY)	BN4-BJ8	8.00
ENG-012	FLYWHEEL TAB WASHER	BN1-BJ8	2.00
ENG-069	ENGINE ID FASTENER (SPECIFY MODEL)	BN1-BJ8	0.85



FUEL

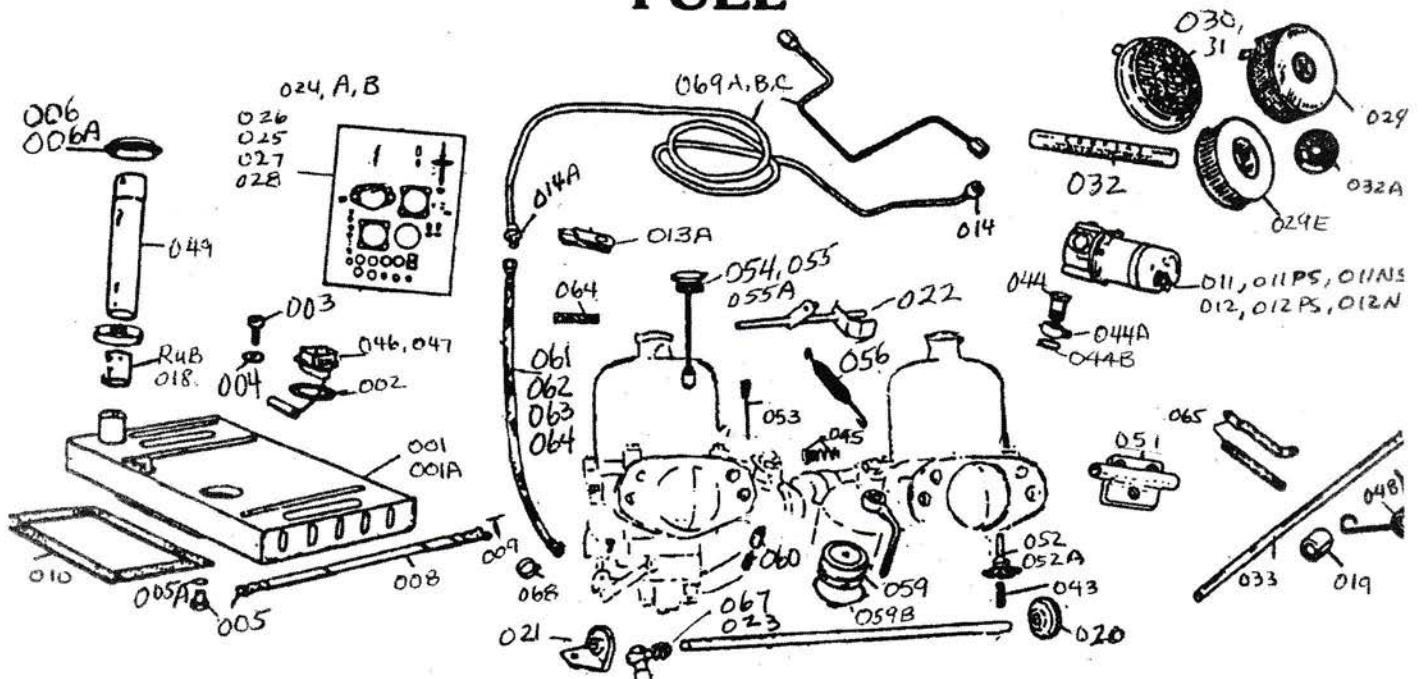

GAS TANKS (aluminum version also available, please call for price)

FUL-001	STEEL GAS TANK (MADE IN UK)	BN1-BN2	990.00
FUL-001A	STEEL GAS TANK (MADE IN UK)	BN4-BJ8	800.00
FUL-001T	STEEL GAS TANK	BN4-BJ8	250.00
FUL-049	GAS TANK FILLER TUBE	BN4-BJ8	65.00
FUL-005	GAS TANK PLUG	BN1-BJ8	5.00
FUL-005A	GAS TANK PLUG COPPER WASHER	BN1-BJ8	0.50
FUL-008	GAS TANK STRAP	BN1-BJ8	35.00
FUL-009	GAS TANK STRAP CLEVIS PIN	BN1-BJ8	1.25
FUL-007	GAS TANK STRAP FIREWALL BRKT	BN1-BJ8	15.00
FUL-010A	GAS TANK FOAM PAD	BN1-BJ2	22.00
FUL-010	GAS TANK FOAM PAD	BN4-BJ8	22.00
FUL-002	GAS TANK SENDING UNIT GASKET	BN1-BJ8	1.10
FUL-003	TANK SENDING UNIT COPPER WASHER	BN1-BJ8	0.80
FUL-004	TANK SENDING UNIT SCREW	BN1-BJ8	1.00
FUL-046	SENDING UNIT (upgraded)	BN1-BJ7	85.00
FUL-047	SENDING UNIT (upgraded)	BJ8	85.00

FUEL PUMPS

FUL-011	FUEL PUMP (DUAL POLARITY)	BN1-BN4	350.00
FUL-011PS	ELECTRONIC VERSION POSITIVE GRND	BN1-BN4	390.00
FUL-011NS	ELECTRONIC VERSION NEGATIVE GRND	BN1-BN4	390.00
FUL-012	FUEL PUMP (DUAL POLARITY)	BN4-BJ8	350.00
FUL-012PS	ELECTRONIC VERSION POSITIVE GRND	BN4-BJ8	390.00
FUL-012NS	ELECTRONIC VERSION NEGATIVE GRND	BN4-BJ8	390.00

FUL-042	FUEL PUMP MOUNTING BOLT	BN1-BJ8	1.50
FUL-071A	FUEL PUMP MOUNTING BRACKET	BN4	20.00
FUL-071	FUEL PUMP MOUNTING BRACKET	BN7-BJ8	35.00
FUL-044	BANJO ADAPTOR	BN4-BJ8	22.00
FUL-044A	BANJO BOLT	BN4-BJ8	5.00
FUL-044B	BANJO BOLT FIBER WASHER	BN4-BJ8	0.75

FUEL HOSES, LINES & FITTINGS

FUL-069A	FUEL LINE KIT	BN1-BN2	150.00
FUL-069B	FUEL LINE KIT—PUMP ON LH SIDE	BN4-BT7	160.00
FUL-069C	FUEL LINE KIT—PUMP ON RH SIDE	BJ7-BJ8	160.00
FUL-013	FUEL LINE CLIP	BN1-BJ8	1.10
FUL-013A	FUEL LINE CLIP	BJ8	1.10
FUL-014	FUEL LINE FITTING (OLIVE & NUT)	BN1-BJ8	7.50
FUL-014A	FUEL LINE FITTING (THREADED END)	BN1-BJ8	12.00
FUL-017	FUEL PUMP LINE ELBOW FITTING	BN4-BJ8	12.00
FUL-018	FUEL PUMP DOUBLE FITTING (SPliced LINE)		5.00

FUL-061	PETROFLEX:FUEL LINE TO CARB	BN1-BN2	45.00
FUL-062	PETROFLEX:FUEL LINE TO CARB	BN4-BT7	30.00
FUL-073	PETROFLEX:FRONT TO CENTER CARB	TRI-CARB	28.00
FUL-063	PETROFLEX:FUEL LINE TO CARB	BJ7-BJ8	35.00
FUL-064	PETROFLEX:BETWEEN CARBS	BJ7-BJ8	10.00
FUL-068	PETROFLEX CLAMP	BN1-BJ8	1.20

CARBS & LINKAGES

FUL-023	THROTTLE ROD BALL JOINT	BN4-BJ8	13.00
FUL-083	THROTTLE ROD BALL JOINT	BN1-BJ2	38.00
FUL-023A	THROTTLE ROD (CUT TO LENGTH)	BN4-BJ8	11.00
FUL-056	THROTTLE, CHOKE RETURN SPRING	BJ7-BJ8	2.50
<i>EACH OF THESE MAJOR SU KIT DOES ONE CARB:</i>			
FUL-024	H4 CARB KIT	BN1-BN2	125.00
FUL-024B	H6 CARB KIT (LAMANS)	BN2	135.00
FUL-024A	H4 CARB KIT (LONGBRIDGE)	BN4	125.00
FUL-026	HD6 CARB KIT	BN4-BT7	120.00
FUL-025	HS4 CARB KIT (TRI-CARB)		75.00
FUL-027	HS6 CARB KIT	BJ7	85.00
FUL-028	HD8 CARB KIT	BJ8	105.00
FUL-033	THROTTLESHAFT (PLS. SPECIFY TYPE OF CARB)		24.00
FUL-038A	THROTTLE SHAFT BUSH	HS6, HD6	2.20
FUL-038	THROTTLE SHAFT BUSH	HD8	3.00
FUL-039	THROTTLE SHAFT SCREW		1.50
FUL-052A	JET (DIAPHRAM)	HD6	45.00
FUL-052	JET (DIAPHRAM)	HD8	45.00
FUL-043	JET SPRING	HD CARB	1.85
FUL-053	JET NEEDLE (PLS. SPECIFY TYPE OF CARB)		13.50
FUL-054	DAMPER/PISTON	BN4-BT7	25.00
FUL-055A	DAMPER/PISTON	BJ7	30.00
FUL-055	DAMPER/PISTON	BJ8	40.00
FUL-022	CARB LINKAGE SHAFT	BJ8	30.00
FUL-072	CARB LINKAGE SHAFT STOP	BJ8	5.00
FUL-045	FUEL BOWL FILTER	BN1-BJ8	9.00
FUL-058	FUEL BOWL LEVER		8.00
FUL-059B	FUEL BOWL FLOAT (BRASS)	HS6, HS4	22.00
FUL-059	FUEL BOWL FLOAT (BRASS)	H4, HD6,8	26.00
FUL-059N	FUEL BOWL FLOAT (NITROPHYL)		18.00
FUL-070	FUEL BOWL LID (FRONT/REAR)	HD CARB	90.00
FUL-060	FUEL BOWL NEEDLE & SEAT		19.00
FUL-065	CARB TO FUEL BOWL BRACKET SET	BN1-BN2	50.00
FUL-076	CARB OVERLOW PIPE		3.00
FUL-077	TRI CARB BALANCE TUBE RUBBER HOSE		4.00

FUEL (CONT.)

AIR CLEANERS

FUL-029	AIR CLEANER (FRONT/REAR)	BN1-BN4	110.00
FUL-030	AIR CLEANER (FRONT/REAR)	BN4-BJ7	75.00
FUL-031A	AIR CLEANER	TRI-CARB	75.00
FUL-031	AIR CLEANER (FRONT/REAR)	BJ8	75.00
FUL-029E	AIR CLEANER PAPER ELEMENT	BN1-BN2	13.00
FUL-032A	BURGESS AIR CLEANER DECAL	BN1-BN2	5.00
FUL-052	COOPER AIR CLEANER DECAL	BN4-BJ8	8.50

MISCELLANEOUS

See p. 4 "cable section" for choke cables and connectors

FUL-074	GAS PEDAL	BN1-BN2	60.00
FUL-051	GAS PEDAL BRACKET (FLOOR)	BN1-BN2	30.00
FUL-048	GAS PEDAL SPRING	BN4-BJ8	10.00
FUL-006A	GAS CAP	BN1-BN2	70.00
FUL-006	GAS CAP	BN4-BJ8	20.00
FUL-016	FITTING FOR MANIFOLD DRAINAGE PIPE	BN1-BJ8	1.10
FUL-015	DRAINAGE PIPE (MANIFOLD)	BN1-BJ8	5.00
FUL-015A	DRAIN PIPE BRACKET: SUMP	BN4-BJ8	5.00
FUL-020	THROTTLE LINK BUSH (FIREWALL)	BN4-BJ8	7.00
FUL-021	THROTTLE LINK BUSH (MANIFOLD)	BN4-BJ8	4.00
FUL-019A	THROTTLE BUSH (NYLON)	BJ8	7.00
FUL-019	THROTLE BUSH (FELT)	BN4-BJ7	3.00
FUL078	SPRING BRACKET (SET)	TRICARB	20.00

SEE ALSO CABLE SECTION FOR CHOKE CABLES

LIGHT

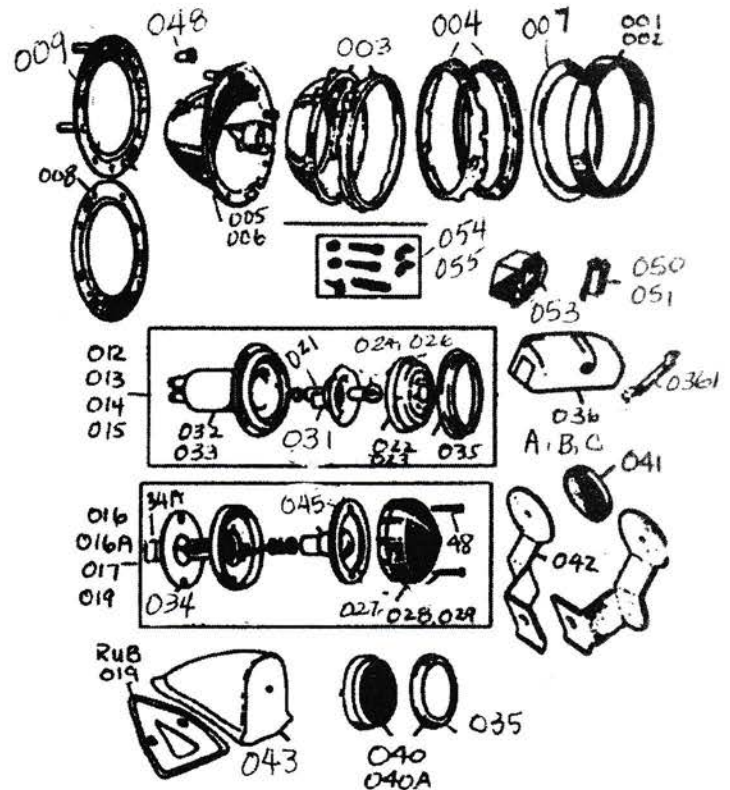

LIGHT

HEADLIGHT/FOG LIGHT/DRIVING LIGHT

LHT-001	HEADLIGHT RIM	BN1-BN2	30.00
LHT-002	HEADLIGHT RIM	BN4-BJ8	60.00
LHT-010	HEADLIGHT RIM SCREW CATCH	BN1-BJ8	3.00
LHT-007	HEADLIGHT RIM DUST EXCLUDER	BN1-BJ8	3.00
LHT-004	3-ADJUSTER INNER RIM	BN1-BJ7	35.00
LHT-003	2-ADJUSTER INNER RIM	BJ8	30.00
LHT-055	3-ADJUSTER SCREW SET	BN1-BT7	12.00
LHT-054	2-ADJUSTER SCREW SET	BJ8	6.00
LHT-008	3-ADJUSTER HEADLIGHT - BODY GASKET	BN1-BJ7	7.50
LHT-009	2-ADJUSTER HEADLIGHT - BODY GASKET	BJ8	6.50
LHT-006	3-ADJUSTER HEADLIGHT BUCKET	BN1-BJ7	25.00
LHT-005	2-ADJUSTER HEADLIGHT BUCKET	BJ8	25.00
LHT-048	HEADLIGHT MOUNTING BRASS NUT	BN1-BJ8	4.50
LHT-061	SUB ASSEMBLY 2 ADJUSTER		95.00

LHT-056	DRIVING LIGHT	BN1-BJ8	170.00
LHT-057	FOG LIGHT	BN1-BJ8	170.00

TURN SIGNAL

LHT-012	CLEAR LENS ASSEMBLY	BN1-BN2	40.00
LHT-013	RED LENS ASSEMBLY	BN1-BN2	40.00
LHT-014	CLEAR LENS ASSEMBLY	BN4-BJ7	40.00
LHT-015	RED LENS ASSEMBLY	BN4-BJ7	40.00
LHT-016	CLEAR LENS ASSEMBLY (DUAL FUNCTION)	BJ8	45.00
LHT-016A	CLEAR LENS ASSEMBLY (SINGLE FUNCT)	BJ8	45.00
LHT-019	RED LENS ASSEMBLY	BJ8	45.00
LHT-017	AMBER LENS ASSEMBLY	BJ8	45.00
LHT-022	CLEAR LENS	BN1-BN2	13.00
LHT-023	RED LENS	BN1-BN2	15.00
LHT-026	CLEAR LENS	BN4-BJ7	13.00
LHT-024	RED LENS	BN4-BJ7	13.00
LHT-027	AMBER LENS	BJ8	15.00
LHT-028	CLEAR LENS	BJ8	15.00
LHT-029	RED LENS	BJ8	15.00
LHT-020	LENS SCREW & NUT	BJ8	3.00
LHT-035	CHROME RETAINER RIM FOR LENS	BN1-BJ7	4.00

BULB HOLDER

LHT-021	BULB HOLDER	BN1-BN2	18.50
LHT-031	BULB HOLDER	BN4-BJ7	10.00
LHT-032	BULB HOLDER TO BODY GASKET	BN1-BN2	6.00
LHT-033	BULB HOLDER TO BODY GASKET	BN4-BJ7	6.00
LHT-034	BULB HOLDER TO BODY GASKET	BJ8	3.00
LHT-034A	BULB HOLDER SOCKET BOOT	BJ8	2.50
LHT-045	BULB HOLDER FOAM GASKET	BJ8	2.00
LHT-060	BULB HOLDER WIRING CONNECTOR	BN1-BJ8	0.75

FLASHER

LHT-030	DASH BULB HOLDER (2 WIRES)	BN1-BJ8	11.00
LHT-030A	DASH BULB HOLDER (1 WIRE)	BN1-BJ8	11.00
LHT-050	FLASHER UNIT (SCREW ON ENDS)	BN1-BJ7	15.00
LHT-051	FLASHER UNIT (PUSH ON ENDS)	BJ8	13.00
LHT-053	FLASHER RELAY BOX (LUCAS)	BN1-BJ8	135.00

LICENSE PLATE LIGHT ASSEMBLY

LHT-036	LICENSE PLATE LIGHT ASSEMBLY	BN1-BJ8	40.00
LHT-036A	MOUNTING BRACKET	BN4-BJ8	12.00
LHT-036B	CHROME COVER	BN1-BJ8	13.00
LHT-036C	GLASS LENS	BN1-BJ8	7.00

BULB

LHT-037	INSTRUMENT BULB (SCREW IN)	BN1-BJ8	1.10
LHT-037A	INSTRUMENT BULB (PUSH ON)	BN1-BJ8	1.00
LHT-038A	TURN SIGNAL BULB (DUAL FUNCTION)	BN1-BJ8	1.10
LHT-038	TURN SIGNAL BULB (RUNNING LIGHT)	BJ8	1.10
LHT-038B	TURN SIGNAL BULB (TURN SIGNAL)	BJ8	1.10
LHT-039	LICENSE PLATE LIGHT BULB	BN1-BJ8	1.10

REAR REFLECTOR

LHT-043	REFLECTOR POD (LH/RH)	BN1-BN2	95.00
LHT-040A	REFLECTOR	BN1-BN2	30.00
LHT-040	REFLECTOR FOR SHROUD	BN4-BJ8	45.00
LHT-041	REFLECTOR FOR BUMPER	BJ8	30.00
LHT-042	REFLECTOR BRACKET: BUMPER (LH/RH)	BJ8	24.00
LHT-035	CHROME RIM FOR REFLECTOR	BJ8	4.00



HYDRAULIC: BRAKE & CLUTCH

HANDBRAKE CABLE COMPONENTS: SEE CABLE SECTION
EACH WHEEL CYLINDER KITS WILL DO BOTH SIDES

HOSES, LINES, CLIPS & BRACKETS

HYD-001	BRAKE HOSE (FT., RR)	BN1-BT7	20.00
HYD-002	FRONT BRAKE HOSE	BJ7-BJ8	20.00
HYD-003A	REAR BRAKE HOSE	BN6-BN7	18.00
HYD-003	REAR BRAKE HOSE	BJ8	20.00
HYD-004	BRAKE HOSE TO CHASIS BRACKET	BN1-BJ8	10.00
HYD-009	BRAKE HOSE COPPER WASHER	BN1-BJ8	0.55
HYD-038	BRAKE LINE CLIPS	BN1-BJ8	0.76
HYD-008	UNION TO LH FRONT BRAKE LINE	BN7-BJ8	18.00
HYD-018A	CALIPER LINE	BN7-BJ8	16.00
HYD-026A	LONG REAR WHEEL CYLINDER LINE	BN1-BJ8	26.00
HYD-071	SHORT REAR WHEEL CYLINDER LINE	BN1-BJ8	18.00
HYD-040	SERVO LINE	BJ8	20.00
HYD-070	FRONT TO REAR LINE	BN4-BJ8	30.00
HYD-065B	RESERVOIR TO MASTER CYLINDER LINE	BN1-BN2	35.00
HYD-065A	RESERVOIR TO MASTER CYLINDER LINE	BN4-BJ8	35.00
HYD-075	BRAKE LINE SET (PLS. SPECIFY MODEL)	BN1-BJ8	195.00

ALL LINES ARE COPPER WITH NICKLE PLATING. COME WITH ENDS

FRONT BRAKES: 100 & 100-6

HYD-019K	7/8" CYLINDER REP KIT	BN1-BN2	29.00
HYD-019	7/8" CYLINDER (LH/RH)	BN1-BN2	50.00
HYD-021K	1" CYLINDER REP KIT	BN1-BN6	25.00
HYD-021	1" CYLINDER (LH/RH)	BN1-BN6	36.00
HYD-021A	DISC WHEEL CYLINDER	BN4-BN6	70.00
HYD-021AK	DISC WHEEL CYL. REP KIT	BN4-BN6	31.00
HYD-027	CYLINDER BLEED SCREW	BN1-BJ8	3.00
HYD-009	CYLINDER BLEED SCREW CAP	BN1-BJ8	1.25
HYD036AR	FR SHOES (SET) SEND CORE FOR REB	BN1	95.00
HYD036B	FR SHOES (SET)	BN2-BN4	80.00

FRONT BRAKES: 3000

HYD-014	CALIPER BLEED SCREW	BT7-BJ8	3.50
HYD-009	BLEED SCREW CAP	BN1-BJ8	0.75
HYD015SS	CALIPER PISTON (STAINLESS)	BT7-BJ8	30.00
HYD016SS	CALIPER PISTON (STAINLESS)	BJ8***	30.00
HYD-017	CALIPER KIT (TRW)	BT7-BJ8	45.00
HYD-018	CALIPER KIT (TRW)	BJ8***	45.00
HYD-023A	CALIPER BOLT	BT7-BJ8	12.00
HYD-023	CALIPER BOLT	BJ8**	18.00
HYD-073	CALIPER (LH/RH)	BT7-BJ8	160.00
HYD-074	CALIPER (LH/RH) STAINLESS PISTONS	BJ8***	105.00

HYD-028	BRAKE ROTOR	BT7-BJ8	47.00
HYD-029	BRAKE ROTOR	BJ8***	50.00
HYD-034	BRAKE PAD KEEPER PIN	BN7-BJ8	4.00
HYD-035	BRAKE PAD KEEPER PIN CLIPS	BN7-BJ8	1.00
HYD-030	BRAKE PAD SET (MINTEX)	BN7-BJ8	50.00
HYD-031	BRAKE PAD SET (MINTEX)	BJ8	60.00
HYD-032	BRAKE PAD FITTING KIT	BN7-BJ8	30.00
HYD-033	BRAKE PAD FITTING KIT	BJ8	10.00

MASTER CYLINDERS & SERVO

HYD-041	REPLACEMENT SERVO	BJ8	515.00
HYD-041B	SERVO VACUUM HOSE	BJ8	15.00
HYD-056	SERVO/BREATHER HOSE CLAMP	BJ8	6.00
HYD-043	BRAKE MASTER CYLINDER (TRW)	BN1-BN2	270.00
HYD-044	BRAKE MASTER CYLINDER REPAIR KIT	BN1-BN2	12.00
HYD-045A	BRAKE MASTER CYL. (SEP. RESERVOIR)	BN4	60.00
HYD-046	BRAKE MASTER CYLINDER REPAIR KIT	BN4-BN6	20.00
HYD-047	BRAKE MASTER CYLINDER	BN7-BJ8	40.00
HYD-048	REPAIR KIT FOR ABOVE	BN4-BJ8	20.00
HYD-058	MASTER CYLINDER PUSH ROD	BN4-BJ8	12.00
HYD-049	BRAKE MASTER CYLINDER (TRW)	BJ8	110.00
HYD-050	BRAKE MASTER CYLINDER REPAIR KIT	BJ8	15.00
HYD-042	MASTER CYLINDER PACKING	BN4-BJ8	4.40
HYD-052	CLEVIS PIN FOR MASTER CYLINDER	BN4-BJ8	1.00

REAR BRAKES

HYD-037	REAR SHOES RETURN SPRING	BN2-BJ8	8.75
HYD-036CR	RR SHOES (SET) SEND CORES FOR REB.	BN1*	85.00
HYD-036	REAR SHOES (SET)	BN1**BJ8	54.00
HYD-020	BRAKE ADJUSTER	BN1-BJ8	90.00
HYD-022A	REAR WHEEL CYLINDER	BN1*	40.00
HYD-021K	REAR WHEEL CYLINDER REPAIR KIT	BN1*	30.00
HYD-022	REAR WHEEL CYLINDER	BN1**BN6	22.00
HYD-022K	REAR WHEEL CYLINDER REPAIR KIT	BN1**BN624.00	
HYD-024	REAR WHEEL CYLINDER	BT7-BJ8	20.00
HYD-024K	REAR WHEEL CYLINDER REPAIR KIT	BT7-BJ8	15.00
HYD-025A	REAR WHEEL CYL DUST SEAL (LH/RH)	BN1*	25.00
HYD-025	REAR WHEEL CYLINDER DUST SEAL	BN1**BJ8	1.50
HYD-039	FELT STEADY POST	BN1**BJ8	1.45

MISCELLANEOUS

HYD-060	SILICON BRAKE FLUID (QT)	BN1-BJ8	40.00
HYD-061	BRAKE FLUID RESERVOIR CAP GASKET	BN1-BJ8	1.60
HYD-062	BRAKE FLUID RESERVOIR CAP	BN1-BJ8	7.00
HYD-064	BRAKE FLUID RESERVOIR	BN1-BN2	90.00
HYD-065	BRAKE FLUID RESERVOIR	BN4-BJ8	100.00
HYD-066	BRAKE FLUID RESERVOIR HOLDER	BN4-BJ8	12.00
HYD-066A	BRAKE FLUID RESERVR STICKER DECAL.	BN1-BN6	7.00
HYD-066B	BRAKE FLUID RESERVOIR DECAL	BN7-BJ8	3.50
HYD-072	HAND BRAKE LEVER	BN4-BJ8	350.00
HYD-006	HAND BRAKE LEVER SCREW	BN1-BJ8	1.00
HYD-067	BRAKE DRUM SCREW	WIRE WHEEL	0.85
HYD-068	BRAKE DRUM SCREW	DISC WHEEL	0.85

*to BN1 221535 **BN1 221536 onwards ***BJ8 26705 onwards

CLUTCH

HYD-047	MASTER CYLINDER	BN4-BJ8	40.00
HYD-048	REPAIR KIT FOR CLUTCH MASTER CYL	BN4-BJ8	12.00
HYD-053	SLAVE CYLINDER	BN4-BJ8	45.00
HYD-054	SLAVE CYLINDER REPAIR KIT	BN4-BJ8	6.00
HYD-027	CYLINDER BLEED SCREW	BN4-BJ8	3.00
HYD-052	MASTER CYL CLEVIS PIN	BN4-BJ8	1.00
HYD-052A	SLAVE CYL CLEVIS PIN	BN4-BJ8	1.00
HYD-051	SLAVE CYLINDER PUSH ROD	BN4-BJ8	10.00
HYD-055	SLAVE CYLINDER RUBBER HOSE	BN4-BJ8	19.00
HYD-010	CLUTCH SLAVE CYLINDER METAL LINE	BN4-BJ8	33.00
HYD-058	CLUTCH MASTER CYL. PUSH ROD	BN4-BJ8	15.00

MISCELLANEOUS

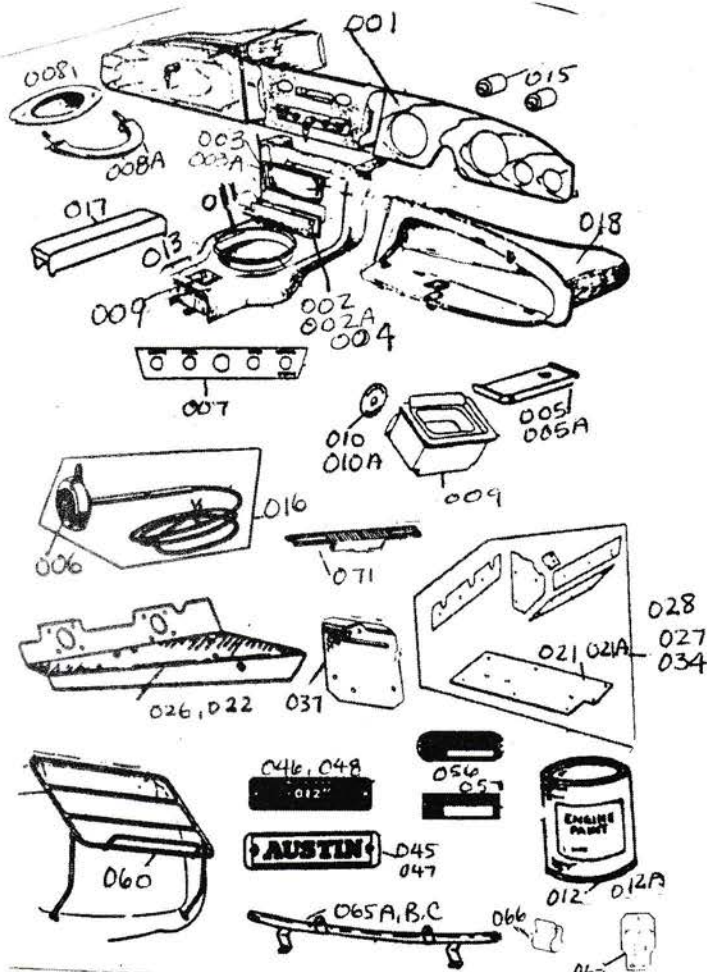

SEAT BELTS

MIS-042	CHROME SHOULDER HARNESS ADAPTRS	BN4-BJ8	98.00
MIS-040	SHOULDER HARNESS BELT 2-SEAT SET	BN4-BJ8	135.00
MIS-041	LAP BELT 2-SEAT SET	BN1-BJ8	75.00
MIS-043	ACORN NUT FOR SEATS & REAR PANEL	BN1-BJ8	2.00

ACCESSORIES

MIS-059	LAMANS BONNET STRAP & CHROME ENDS	BN1-BN2	190.00
MIS-060	ORIGINAL STYLE LUGGAGE RACK	BN4-BJ8	450.00
MIS-009	ASH TRAY	BN1-BJ8	135.00
MIS-014	KEY FOB		16.00

ID PLATES

MIS-056	CHASSIS ID PLATE (OVAL)		12.00
MIS-057	CHASSIS ID PLATE (RECTANGULAR)		10.00
MIS-058	CHASSIS ID PLATE (OVAL, LATE BJ8)		12.00

CAR COVERS

MIS-061	EXTERIOR CAR COVER		280.00
MIS-061A	MEDIUM PROTECTION CAR COVER		170.00
MIS-061B	CAR COVER (INTERIOR USE)		130.00
MIS-063A	TRIGUARD CAR COVER		70.00
MIS-062	CABLE & LOCK FOR CAR COVER		10.00

BADGE BARS

MIS-065A	BADGE BAR WITH FOG LIGHT FIXTURES	BN1-BN2	260.00
MIS-065B	BADGE BAR WITH FOG LIGHT FIXTURES	BN4-BJ8	260.00
MIS-065C	BADGE BAR (SHORTENED, NO LIGHT FIXTURES)		150.00
MIS-066	BADGE BAR CLIP		5.50
MIS-067	BADGE BAR CLIP MOUNTING PLATE		8.00

LICENSE PLATES MOUNTING BRACKET

MIS-070	FRONT BRACKET (ENGLISH STYLE)		55.00
MIS-070A	FRONT BRACKET		65.00
MIS-071	REAR BRACKET (MOUNT ON SHROUD)		28.00
MIS-071A	REAR BRACKET WITH LICENSE LIGHT HOLDER		140.00

HEATSHIELDS

MIS-037	MANIFOLD HEATSHIELD PLATE	BN1-BN2	25.00
MIS-026	CARB HEATSHIELD	BN4-BJ8	25.00
MIS-022	CARB HEATSHIELD SET	TRICRB	60.00
MIS-021A	FLOOR HEATSHIELD	BN1-BN2	70.00
MIS-021	FLOOR HEATSHIELD	BN4-BJ8	70.00
MIS-034	FLOOR & FIREWALL HEATSHIELD	BN1-BN2	190.00
MIS-027	FLOOR & FIREWALL HEATSHIELD	BN4-BJ7	200.00
MIS-028	FLOOR & FIREWALL HEATSHIELD	BJ7-BJ8	200.00
MIS-030	DYNAMAT (SOUND, HEATPROOF) PER SECT.	BN1-BJ8	28.00

DASH: BN1-BJ7 (SEE ALSO SWITCHES SECTION)

MIS-005A	UNDER DASH METAL PARCEL TRAY	BN1-BN2	75.00
MIS-005	UNDER DASH METAL PARCEL TRAY	BN4-BJ7	75.00
MIS-008A	DASH GRAB HANDLE	BN1-BJ7	40.00
MIS-008	DASH HANDLE CHROME BACKING PLATE	BN4-BJ7	60.00
MIS-010A	"NORMAL/OVERDRIVE" PLATE	BN1	26.00
MIS-010	"NORMAL/OVERDRIVE" PLATE	BN2-BJ7	35.00
STR-032	CHROME STEERING COLUMN RING	NON-ADJ	40.00
STR-043	CHROME STEERING COLUMN RING	ADJ	40.00
MIS-080	INSTRUMENT CLUSTER CHROME RING	BN1-BJ7	175.00
MIS-019	GREEN TURN SIGNAL BLINKER	BN1-BJ7	20.00

DASH: BJ8

MIS-001	WOOD DASH BOARD SET (PREHUNG DOOR)	BJ8	550.00
MIS-018	GLOVE BOX	BJ8	190.00
MIS-050	GLOVE BOX LOCK	BJ8	140.00
MIS-002	RADIO BLANKING PLATE	BJ8	8.00
MIS-002A	RADIO BLANKING PLATE BEZEL	BJ8	9.00
MIS-004	RADIO BLANKING ASSEMBLY	BJ8	40.00
MIS-003A	RADIO SPEAKER SCREEN	BJ8	20.00
MIS-003	RADIO SPEAKER SCREEN BEZEL	BJ8	50.00
MIS-015	GREEN ARROW & SLEEVE	BJ8	25.00
MIS-007	CHROME DASH SWITCHES PANEL	BJ8	48.00
MIS-011	STAINLESS SURROUND FOR GEARSHIFT LEVER		30.00
MIS-017	CENTER ARM REST METAL BASE	BJ8	70.00

GAUGES

GAU-002	SMALL GAUGE O RING	BN1-BJ8	2.00
GAU-003	LARGE GAUGE O RING	BN1-BJ8	2.00
GAU-004	GAUGE THUMB SCREW (SMALL)	BN1-BJ8	3.25
GAU-005	GAUGE THUMB SCREW (LARGE)	BN1-BJ8	3.50
GAU-006A,B	GAUGE BEZEL (SMALL)	BN1-BJ8	12.00
GAU-007A,B	GAUGE BEZEL (LARGE)	BN1-BJ8	20.00
GAU-010	GLASS FOR SMALL GAUGE	BN1-BJ8	7.00
GAU-009	GLASS FOR LARGE GAUGE	BN1-BJ8	7.00
GAU-012	FUEL GAUGE BRACKET	BJ8	12.00
GAU-013	SAFETY GAUGE BRACKET	BJ8	15.00
GAU-014	SPEEDO & TECH GAUGE BRACKET	BJ8	10.00
GAU-008	CLIP FOR WATER TEMP GAUGE LINE	BN4-BJ8	3.00

TURN SIGNAL/HORN

MIS-016	TURN SIGNAL ASSEMBLY: ADJ. STERING		550.00
MIS-006	HORN BUTTON FOR ADJ. STEERING		38.00
MIS-031	TURN SIGNAL LEVER	BN1BN2	45.00
MIS-032	TURN SIGNAL LEVER FOR ADJ STEERING		50.00

MIRROR

MIR-010	DASH MIRROR MOUNTING BRACKET	BN1-BN2	20.00
MIR-001	DASH MIRROR	BN1-BJ8	40.00
MIR-002	DASH MIRROR	BJ8	40.00
MIR-003	DASH MIRROR RISER	BJ8	60.00

SIDE VIEW MIRRORS

MIR-004	LUCAS STYLE FENDER MIR:FLAT GLASS (LH/RH)		50.00
MIR-005	LUCAS STYLE FENDER MIR:CONV GLASS (LH/RH)		50.00
MIR-007	LUCAS STYLE DOOR MIRROR	BN1-BJ8	50.00
MIR-006	FENDER MIRROR GROMMET	BN1-BJ8	1.80

MIR-013	SIDE MIRROR (SIDE CURTAIN SOCKET)	BN4-BJ7	70.00
MIR-009	"CLIP ON" SIDE VIEW MIRROR	BJ7-BJ8	45.00
MIR-008	"BULLET" MIRROR	BN1-BJ8	70.00

RUBBER

RUB-001	BONNET/FENDER BUFFER WITH PIN	BN1-BJ8	1.95
RUB-002	BONNEL SEAL	BN4-BJ8	7.00
RUB-025	BONNET RELEASE ROD GROMMET SET	BN1-BJ8	4.40
RUB-003	BONNET OR TRUNK PROP ROD STAY	BN1-BJ8	1.00
RUB-004	BONNET OR TRUNK PROP ROD GROMMET	BN1-BJ8	1.00
RUB-007	TRANS. TUNNEL RECTANGULAR PLUG	BN1-BJ8	1.75
RUB-008A	3 SPEED GEAR SHIFT BOOT	BN1	25.00
RUB-008	SIDESHIFT GEAR SHIFT BOOT	BN2-BT7	11.00
RUB-009	CENTERSHIFT GEAR SHIFT BOOT	BT7-BJ8	18.00
RUB-006	TRANS.TUNNEL SPEEDO CABLE GROMMET	BN7-BJ8	3.00
RUB-014A	WIRING HARNESS GROMMET	BN1-BN2	3.00
RUB-014	WIRING HARNESS GROMMET	BN4-BJ8	3.00
RUB-015	STEERING COLUMN GROMMET	BN1-BJ8	2.50
RUB-016	WATER TEMP LINE GROMMET	BN1-BJ8	2.00
RUB-013	GROMMET ASSORTMENT	BN1-BJ8	19.00
RUB-026	MAJOR FIREWALL GROMMET SET (includes RUB-013,014,015 & 016)	BN1-BJ8	20.00
MIS-039	SCUTTLE SEAL TO BODY BRACKET (PAIR)	BN2	85.00
RUB-029	SCUTTLE SEAL (PAIR)	BN2	65.00
RUB-012	SCUTTLE SEAL (PAIR)	BN4-BT7	40.00
RUB-012A	SCUTTLE SEAL RIVET	BN4-BT7	0.83
RUB-011	GAS FILLER TUBE TO BODY GROMMET	BN4-BJ8	4.00
RUB-018	GAS FILLER TUBE TO TANK CONNECTOR	BN4-BJ8	11.00
RUB-030	PEDAL FOAM PAD SET	BN1-BN2	20.00
RUB-017	SPLASH PAN WELTING	BN1-BN2	5.50
RUB-019	REFLECTOR POD PAD	BN1-BN2	5.00
RUB-021	DIP STICK BOOT	BN1-BN2	3.30
RUB-021A	DIP STICK RUBBER WASHER	BN4-BJ8	1.00
RUB-020	STARTER SOLENOID BUTTON BOOT	BN1-BJ8	3.00
RUB-023	STARTER SOLENOID WIRE BOOT	BN1-BJ8	3.00
RUB-024	FUEL LINE GROMMET (IN TRUNK)	BN4-BJ8	4.50
RUB-022	BREATHER PIPE ELBOW	BN4-BJ8	12.00
RUB-010	AH LOGO RUBBER FLOOR MAT	BN1-BJ8	45.00
RUB-005	PEDAL PAD	BN1-BJ8	3.00

STEERING

STEERING WHEELS

STR-001D	MOTO LITA WOOD WHEEL (DARRINGTON)	BN1-BJ8	500.00
STR-001A	MOTO LITA WOOD WHEEL (RALLY)	BN1-BJ8	425.00
STR-001	MOTO LITA WOOD WHEEL (ORIGINA)	BN1-BJ8	425.00
<i>COPIES OF STR-001A & STR-001 ALSO AVAILABLE</i>			

STR-002	ADJUSTABLE HUB ADAPTOR FOR WOOD WHEELS		315.00
STR-003	NON-ADJUSTABLE HUB ADAPTOR		225.00
STR-003P	POLISHED NON-ADJ HUB ADAPTER		250.00

STR-001B	ORIGINAL BLACK WHEEL	ADJ	450.00
MIS-077	BLACK LEATHER STEER WHL COVER		85.00
STR-004	STEERING WHEEL NUT	NON-ADJ	18.00

STEERING COLUMN

STR-045	COMPLETE STEERING COLUMN (SPEC.ADJ/NONADJ)		2600.00 (individual components available, please call for price)
STR-025	STEERING WORM GEAR & SHAFT	BN4-BJ8	800.00

STR-032	DASH CHROME RING: STEER COLUMN	NON-ADJ.	44.00
STR-043	DASH CHROME RING: STEER COLUMN	ADJ.	44.00

STR-031	CHROME COIL SPRING: STEERING COLUMN		40.00
STR-034	UPPER SUPPORT FOR CHROME COIL SPRING		18.00
STR-033	LOWER SUPPORT FOR CHROME COIL SPRNG		12.00
STR-044	RUBBER PACKING STRIP	ADJ	5.60

STR-030	STATOR TUBE NUT	BN1-BJ8	8.00
STR-029	STATOR TUBE OLIVE	BN1-BJ8	5.00

STR-018	PENRITE STEERING BOX FLUID	BN1-BJ8	40.00
---------	----------------------------	---------	-------

*UP TO BN2 230997 ** UP TO BN2 2289931 ***BJ7 19191 ONWARDS

STEERING

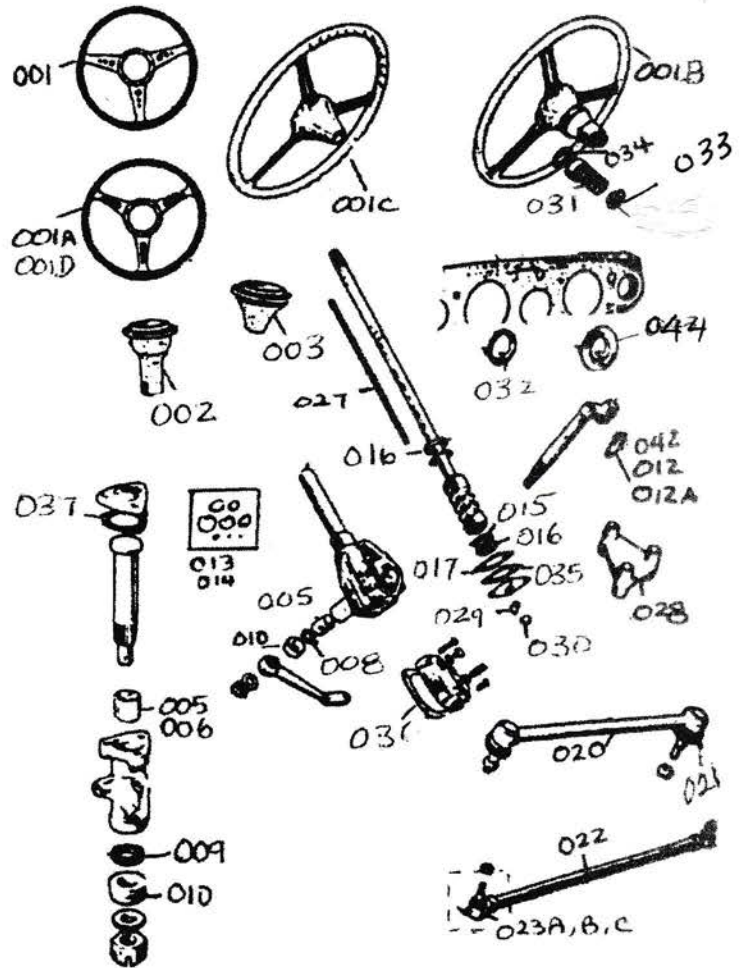

CENTER & SIDE ROD

STR-020	SIDE ROD WITH ENDS	BN1-BJ8	90.00
STR-022	CENTER ROD WITH ENDS	BN4-BT7	95.00
STR-022A	CENTER ROD WITH ENDS	BJ7-BJ8***	120.00
STR-023A	CENTER ROD ENDS:MALE (PAIR)	BN1-BN2**	35.00
STR-023B	CENTER ROD ENDS:MALE (PAIR)	BN2-BT7	35.00
STR-023C	CENTER ROD ENDS:FEMALE (PAIR)	BJ7-BJ8***	35.00
STR-021	CENTER/SIDE ROD BOOT	BN1-BJ8	2.00
STR-019	BOOT FASTENING CLIP	BN1-BJ8	2.50
STR-023	CENTER ROD	BN1-BJ8	60.00

STEERING & IDLER BOX

STR-028	STEERING/IDLER BOX SPACER BRACKET		50.00
STR-046	IDLER BOX ASSEMBLY	BN2-BJ8	280.00
STR-006	IDLER BOX BUSH	BN1-BN2*	7.00
STR-011	STEERING BOX BUSH	BN1-BN2*	53.00
STR-005	STEERING AND IDLER BOX BUSH	BN2-BJ8	11.00
STR-007	STEERING AND IDLER BOX SEAL	BN1-BN2*	3.00
STR-008	STEERING BOX SEAL	BN2-BJ8	6.00
STR-009	IDLER BOX SEAL	BN2-BJ8	5.00
STR-010	STEERING AND IDLER BOX DUST SEAL	BN2-BJ8	4.00
STR-017	STEERING BOX END SHIM	BN4-BJ8	2.20
STR-035	STEERING BOX END GASKET	BN4-BJ8	1.50
STR-036	STEERING BOX TOP GASKET	BN7-BJ8	1.75
STR-037	IDLER BOX GASKET	BN1-BJ8	1.50
STR-042	STEERING BOX PEG	BN1-BN2*	180.00
STR-012	STEERING BOX PEG	BN4-BJ8	95.00
STR-013	STEERING COLUMN BEARING SET	BN1-BN2*	15.00
STR-014	STEERING PEG BEARING SET	BN1-BN2*	15.00
STR-015	STEERING BOX CAGED BEARING	BN2-BJ8	45.00
STR-016	STEERING BOX CAGED BEARING CUP	BN2-BJ8	45.00

SUSPENSION

FRONT SUSPENSION

SUS-002	FRONT END (KING PIN) KIT (BOTH SIDES)	BN1-BJ8	175.00
SUS-059	CORK O RING	BN1-BJ8	1.00
SUS-060	KINGPIN DUST COVER RUBBER O RING	BN1-BJ8	1.10
SUS-015	KINGPIN BUSH (UPPER) PHOS.BRONZE	BN1-BJ8	18.00
SUS-016	KINGPIN BUSH (LOWER) PHOS.BRONZE	BN1-BJ8	18.00
SUS-013	FULCRUM PIN COTTER	BN1-BJ8	3.00
SUS-014	WISHBONE COTTER	BN1-BJ8	3.00

SUS-020	WISHBONE BUSH	BN1-BJ8	2.00
SUS-021	WISHBONE BOLT & WASHER ASSEMBLY	BN1-BJ8	16.00
SUS-070	FRONT WISHBONE MOUNT (LH/RH)	BN1-BN2	80.00
SUS-071	FRONT WISHBONE MOUNT (LH/RH)	BN4-BJ8	80.00
SUS-072	REAR WISHBONE MOUNT (LH/RH)	BN1-BJ8	80.00

COIL SPRINGS

SUS-053	FRONT COIL SPRING	BN1-BJ8	80.00
SUS-053B	FRONT COIL SPRING	BJ8 **	90.00
SUS-054	FRONT COIL SPRING BUMP	BN1-BJ8	11.00

FRONT SHOCKS

SUS-050R	FRONT SHOCK (SEND CORE FOR REB)	BN1-BJ8	160.00
SUS-050	FRONT SHOCK (MINOR MODIF. REQ.)	BN1-BJ8	280.00
SUS-051	FRONT SHOCK MOUNTING PLATE (LH/RH)	BN1-BJ8	75.00
SUS-052	FRONT SHOCK REBOUND BUSH	BN1-BJ8	3.00
SUS-011	UPPER TRUNION BOLT	BN1-BJ8	4.00
SUS-012	UPPER TRUNION BUSH	BN1-BJ8	1.75
SUS-012P	POLY UPPER TRUNION BUSH	BN1-BJ8	2.25

SWAY BAR

SUS-008	ANTISWAY BAR	BN4-BJ8	230.00
SUS-009	ANTISWAY BAR END LINK PLATE (LH/RH)	BN1-BJ8	18.00
SUS-006	ANTISWAY BAR END LINK	BN1-BJ8	12.00
SUS-007	ANTISWAY BAR END LINK BUSH	BN1-BJ8	1.00
SUS-005A	ANTISWAY BAR BUSH (1/2")	BN1-BN2	3.00
SUS-005	ANTISWAY BAR BUSH (5/8")	BN4-BJ8	3.00
SUS-004	ANTISWAY BAR BRACKET	BN1-BJ8	2.00

REAR SUSPENSION

SUS-037	REAR SHOCK (LH/RH) NEW	BN1-BJ8	190.00
SUS-037R	REAR SHOCK (LH/RH) REBUILT	BN1-BJ8	120.00
SUS-038	REAR SHOCK (LH/RH) NEW	BJ8**	190.00
SUS-038R	REAR SHOCK (LH/RH) REBUILT	BJ8**	120.00
SUS-039	REAR SHOCK LINK ARM	BN1*	50.00
SUS-040A	REAR SHOCK LINK ARM	BN1-BJ8	40.00
SUS-040	REAR SHOCK LINK ARM	BJ8**	40.00
SUS-042	REAR SHOCK MOUNTING BRACKET	BJ8**	45.00
SUS-056	REAR SHOCK MOUNTING PLATE	BN1-BN2	60.00
SUS-057	REAR SHOCK MOUNTING PLATE	BN4-BJ8	60.00
SUS-058	REAR SHOCK MOUNTING PLATE	BJ8**	60.00

SUS-063	REAR AXLE REBOUND PAD	BN4-BJ8	6.00
SUS-033B	REAR AXLE BUMP	BN1	70.00
SUS-033	REAR AXLE BUMP	BN1-BJ8	20.00
SUS-033A	REAR AXLE BUMP	BJ8**	8.00
SUS-034	RADIUS ARM BUSH	BJ8**	16.00
SUS-035	RADIUS ARM BOLT	BJ8**	2.75

LEAF SPRINGS

SUS-022	LEAF SPRING (PAIR)	BN1-BN2	350.00
SUS-023	LEAF SPRING (PAIR)	BN4-BJ8	425.00
SUS-024	LEAF SPRING (PAIR)	BJ8**	425.00
SUS-041	LEAF SPRING WEDGE	BN1*	25.00
SUS-026	LEAF SPRING BUSH	BN1-BJ8	7.00
SUS-027	LEAF SPRING BOLT	BN1-BJ8	5.00
SUS-031	LEAF SPR SHACKLE BUSH FOR CHASSIS	BN1-BJ7	6.75
SUS-030	LEAF SPRING SHACKLE BOLT	BN1-BJ8	7.00
SUS-046	LEAF SPRING SHACKLE PLATE (IN/OUT)		20.00
SUS-036	LEAF SPRING SHACKLE	BJ8**	45.00
SUS-029	LEAF SPRING SHACKLE BUSH	BJ8**	1.10
SUS-028	LEAF SPRING RUBBER PAD	BJ8	4.00
SUS-025	LEAF SPRING FIBER PACKING	BN1-BJ8	5.00
SUS-032	LEAF SPRING U BOLT	BN1-BJ8	6.50

*UP TO BN1 221535

**BJ8 26705 ONWARD

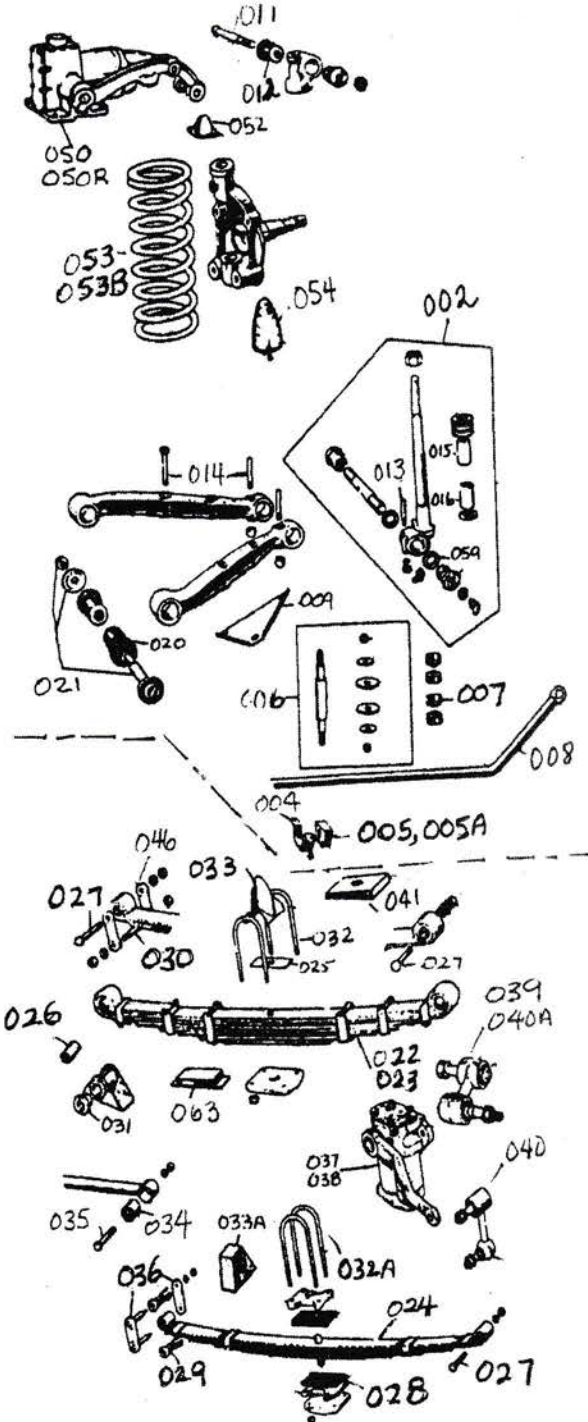
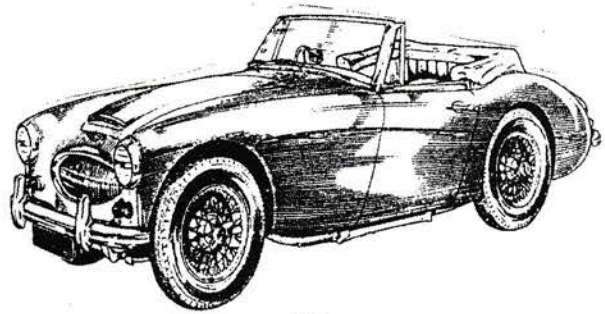

SWITCHES

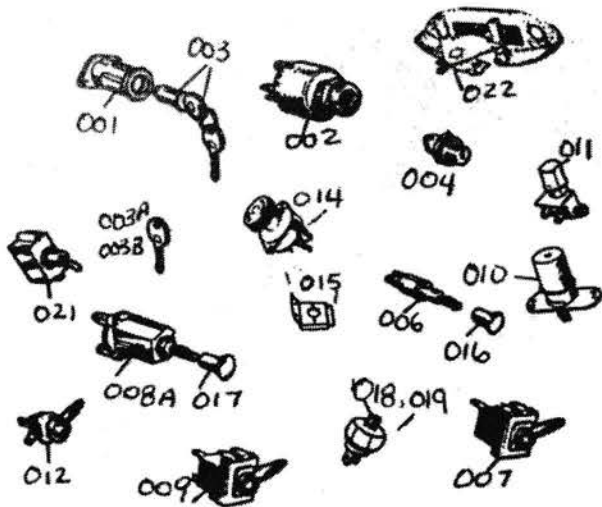

TRUNK

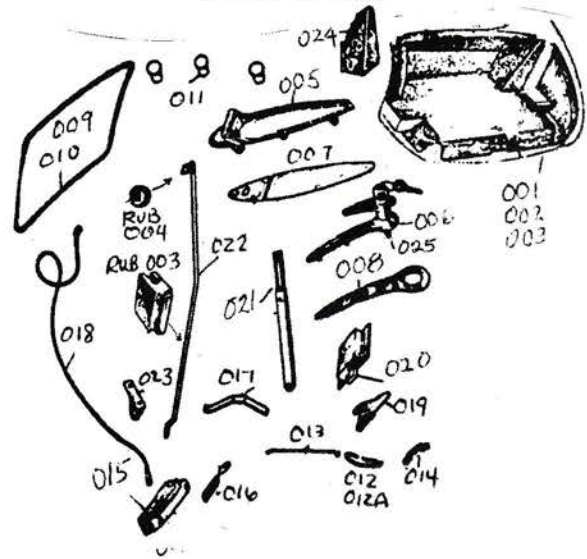

SWT-001	IGNITION SWITCH	BN1-BJ7	36.00	TRK-021	TRUNK LID TELESCOPIC STAY	BN1-BN2	50.00
SWT-002	IGNITION SWITCH	BJ8	25.00	TRK-018	TRUNK LID LIMITER CABLE	BN4-BJ8	30.00
SWT-003	IGNITION SWITCH KEY & TUMBLER	BN1-BJ8	13.00	TRK-022	TRUNK LID PROP ROD	BN4-BJ8	40.00
SWT-003B	IGNITION KEY BLANK "FP" SERIES		8.00	TRK-005	TRUNK HINGE (L.H/RH)	BN1-BJ8	90.00
SWT-003A	IGNITION KEY BLANK "FS" SERIES		6.00	TRK-007	TRUNK HINGE GASKET	BN1-BJ8	2.20
SWT-004	STARTER BUTTON	BN1-BJ7	13.00	TRK-006	TRUNK HANDLE WITH KEY	BN1-BJ8	100.00
SWT-016	WIPER KNOB	BN1-BJ7	6.00	TRK-008	TRUNK HANDLE GASKET	BN1-BJ8	1.50
SWT-006	WIPER SWITCH (LUCAS)	BN1-BJ7	23.00	TRK-025	TRUNK HANDLE CUP WASHER	BN1-BJ8	10.00
SWT-007	WIPER SWITCH	BJ8	28.00	TRK-020	TRUNK LOCK	BN1-BJ8	50.00
SWT-005	PANEL LIGHT SWITCH	BN1-BJ7	40.00	TRK-019	TRUNK LOCK STRIKER	BN1-BJ8	59.00
SWT-017	HEADLIGHT DASH KNOB	BN1-BJ7	12.00	TRK-011	TRUNK BUFFER	BN1-BJ8	1.80
SWT-008A	HEADLIGHT DASH SWITCH	BN1-BJ7	39.00	TRK-009	TRUNK SEAL	BN1-BN2	25.00
SWT-009	HEADLIGHT DASH SWITCH	BJ8	35.00	TRK-010	TRUNK SEAL	BN4-BJ8	30.00
SWT-010	HEADLIGHT DIP SWITCH	BN1-BJ7	55.00	TRK-012	SPARE WHEEL STRAP	BN1-BJ8	53.00
SWT-011	HEADLIGHT DIP SWITCH	BJ8	35.00	TRK-012A	SPARE WHEEL STRAP	BN6-BN7	115.00
SWT-013A	HEADLIGHT DIP SWITCH MOUNTING BRKT	BN4-BJ7	20.00	TRK-014	SPARE WHEEL STRAP CHROME BRACKET	BN1-BJ8	9.00
SWT-013	HEADLIGHT DIP SWITCH MOUNTING BRKT	BJ8	20.00	TRK-017	SPARE WHEEL HOLD DOWN BAR	BN1-BN2	40.00
SWT-021	OVERDRIVE DASH SWITCH	BN1-BJ7	20.00	TRK-013	SPARE WHEEL HOLD DOWN BAR	4-SEATER	50.00
SWT-012	OVERDRIVE AND DASH SWITCH	BJ8	9.00	TRK-015	SPARE WHL HOLD DOWN BAR WOOD BLCK	4-SEATER	22.00
SWT-014	BATTERY CUT OFF SWITCH	BN1-BJ8	60.00	TRK-016	SPARE WHL HOLD DOWN BAR BRACKET	4-SEATER	12.00
SWT-015	BATTERY CUT OFF SWITCH MOUNT BRKT	4-SEATER	15.00	TRK-001	TRUNK LINING KIT	BN1-BN2	360.00
SWT-018	BRAKE LIGHT SWITCH	BN1-BJ7	15.00	TRK-003	TRUNK LINING KIT	2-SEATER	580.00
SWT-019	BRAKE LIGHT SWITCH	BJ8	18.00	TRK-002	TRUNK LINING KIT	BN4-BJ8	300.00
SWT-022	HEATER SWITCH	BN4-BJ8	50.00	TRK-024	GAS FILLER PIPE COVER	BN4-BJ8	8.00

TRANSMISSION & OVERDRIVE

SYNCHRONIZERS (BAULK RINGS)

TRN-010	BAULK RING	BN1	180.00
TRN-001	2ND GEAR BRASS SYNCHRO	BN2-BJ7	50.00
TRN-002	3 RD -4TH GEAR BRASS SYNCHRO	BN2-BJ7	60.00
TRN-003	2 ND GEAR STEEL SYNCHRO	BJ8	60.00
TRN-004	3-4 TH GEAR STEEL SYNCHRO	BJ8	70.00

LAYSHAFTS

TRN-058	LAYSHAFT	BN1	250.00
TRN-005	LAYSHAFT	BN2-BJ7	130.00
TRN-006	LAYSHAFT	BJ8	110.00

GEAR

TRN-008	FIRST GEAR ASSEMBLY	BN2-BJ8	750.00
TRN-007	REVERSE GEAR	BN2-BJ8	180.00

RECONDITIONED LAYGEARS ARE AVAILABLE			380.00
TRN-009	LAYGEAR THRUST WASHER (.080;.084;.090)	SDSHFT	32.00

BEARINGS

TRN-012	NEEDLE ROLLER BEARING:LAYGEAR	BN2-BJ7	0.65
TRN-013	NEEDLE ROLLR BEAR:FIRST MOTIONSHT	BN2-BJ7	1.20
TRN-014	NEEDLE ROLLR BEAR:2RD & 3RD GEAR	BN2-BJ8	0.60
TRN-015	CAGED BEARING:	BJ8	13.00
TRN-021	MAINSHAFT BEARING	BN1	35.00
TRN-022	MAINSHAFT BEARING	BN2-BJ8	37.00
TRN-022	FIRST MOTION SHAFT BEARING	BN1	35.00
TRN-023	FIRST MOTION SHAFT BEARING	BN2-BJ8	33.00

GASKETS & SEALS

TRN-029A	3 SPEED GEARBOX & OD GASKET SET	BN1	24.00
TRN-029	SIDESHIFT GEARBOX & OD GASKET SET	BN2-BJ7	22.00
TRN-030	CENTERSHIFT GEARBOX & OD GASKET SET	BT7-BJ8	22.00
TRN-031	BELLEOUSING SEAL	BN2-BJ8	6.50
TRN-031A	INTERLOCK SEAL	BN1	7.00
TRN-059	SELECTOR SHAFT SEAL	CNTRSHFT	10.00

TRANSMISSION & OVERDRIVE

(CON'T)

GEAR SHIFT & KNOBS

TRN-043	SHIFT LEVER SPRING	CNTRSHFT	12.00
TRN-044	SHIFT LEVER SPRING CIRCLIP	CNTRSHFT	14.00
TRN-051	SHIFT LEVER SPRING WASHER	CNTRSHFT	8.00
TRN-072	SHIFT LEVER RUBBER PACKING (THICK)	SIDESHIFT	8.00
TRN-073	SHIFT LEVER RUBBER PACKING (THIN)	SIDESHIFT	8.00
TRN-074	SHIFT LEVER PLATE	SIDESHIFT	30.00
TRN-084	SHIFT LEVER SPACER	SIDESHIFT	5.00
TRN-052A	SHIFT LEVER BRASS BUSH	BN1-BJ7	18.00
TRN-052	SHIFT LEVER NYLON BUSH	BJ8	4.00
TRN-045A	SHIFT KNOB (ORIG. STYLE)	BN1	80.00
TRN-045	SHIFT KNOB (ORIG. STYLE)	BN2-BJ8	13.00
TRN-046	SHIFT KNOB (WOOD WITH EMBLEM)	BN2-BJ8	45.00

MOUNTS

TRN-063	CHASSIS TIE BAR	BN1	32.00
TRN-020	CHASSIS TIE BAR	BN2-BJ8	30.00
TRN-020A	CHASSIS TIE BAR PIN	BN2-BJ8	18.00
TRN-025	CHASSIS TIE BAR RUBBER BUSH	BN1-BJ8	1.25
TRN-026	GEARBOX TIE BAR RUBBER BUSH	BN2-BJ8	1.50
TRN-019	TRANSMISSION MOUNT BRACKET (LH/RH)	BN2-BJ8	45.00
TRN-027	TRANSMISSION RUBBER MOUNT	BN2-BJ8	5.75
TRN-028	TRANSMISSION RUBBER BUFFER	BN2-BJ8	5.00
TRN-027A	TRANSMISSION RUBBER MOUNT & BOLT	BN1	10.00

MISCELLANEOUS

TRN-049	RIGHT ANGLE DRIVE SPEEDO CABLE	BN4-BJ8	60.00
TRN-050	UNIVERSAL JOINT W/ GREASE FITTINGS	BN1-BJ8	20.00
TRN-053	PROP SHAFT TAB WASHER	BN1-BJ8	3.85
TRN-056	PROP SHAFT-DIFFERENTIAL BOLT	BN2-BJ8	1.10
TRN-057	PROP SHAFT-OVERDRIVE BOLT	BN1-BJ8	9.00
TRN-090	GEARSHIFT LEVER (SPECIFY MODEL)		200.00

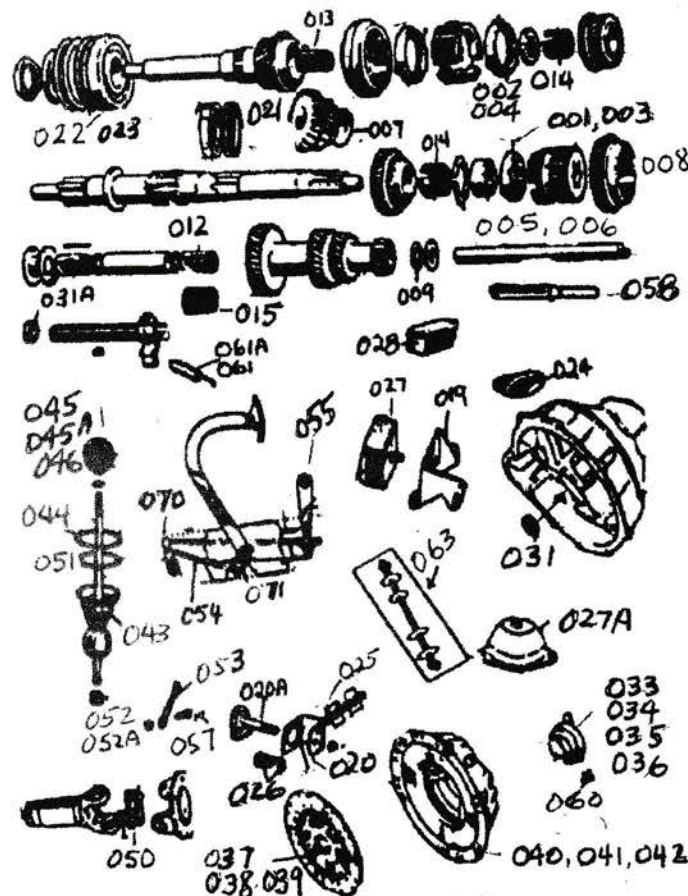

CLUTCH LINKAGES: 100

TRN-070	CLUTCH CON. ROD LEVER (1 HOLE)	BN1-BN2	70.00
TRN-071	CLUTCH RELAY LEVER (2 HOLES)	BN1-BN2	70.00
TRN-054	CLUTCH LINKAGE ROD SET	BN1-BN2	105.00
TRN-055	CLUTCH LINKAGE LEVER BRACKET	BN1-BN2	55.00
TRN-064	CLUTCH RETURN SPRING BRACKET	BN1-BN2	8.00
TRN-065	CLUTCH SHAFT WASHER	BN1-BN2	9.00
TRN-061	CLUTCH PEDAL RETURN SPRING	BN1-BN2	5.00
TRN-066	CLUTCH CROSS SHAFT	BN2	145.00

RELEASE BEARINGS, DISCS & PRESSURE PLATES

TRN-024	CLUTCH RELEASE FORK RUBBER BOOT	BN4-BJ8	7.75
TRN-017	CLUTCH RELEASE FORK REPAIR KIT	BN4-BJ8	50.00
TRN-061A	CLUTCH PEDAL RETURN SPRING	BN4-BJ8	9.00
TRN-033	CLUTCH RELEASE BEARING	BN1	84.00
TRN-035	CLUTCH RELEASE BEARING	BN7-BJ7	80.00
TRN-034	CLUTCH RELEASE BEARING	BN2-BN6, BJ7- BJ8	80.00
TRN-060	CLUTCH RELEASE BEARING CLIP	BN1-BJ8	4.00
TRN-037	CLUTCH DISC	BN1	200.00
TRN-038	CLUTCH DISC	BN2-BN6	220.00
TRN-039	CLUTCH DISC (10")	BN7-BJ7	250.00
TRN-038A	CLUTCH DISC	BJ7- BJ8	220.00
TRN-040	CLUTCH PRESSURE PLATE	BN1-BN6	280.00
TRN-041	CLUTCH PRESSURE PLATE	BN7-BJ7	340.00
TRN-042	CLUTCH PRESSURE PLATE	BJ7- BJ8	240.00
TRN-032	PILOT (SPIGOT) BUSH	BN1-BJ8	4.00

OVERDRIVE

OVD-001	OVERDRIVE SEAL	BN1-BJ8	6.00
OVD-013	OIL PUMP PLUNGER & ROLLER	BN1-BJ8	125.00
OVD-013A	OIL PUMP BODY	BN1-BJ8	115.00
OVD-023R	SLIDING CLUTCH MEMBR (CONE CLUTCH)	BN1-BJ8	250.00
OVD-025	OVERDRIVE SUMP MAGNET	BN1-BJ8	5.00
OVD-024A	OVERDRIVE SUMP FIBER WASHER	BN1-BJ8	2.50
OVD-002	CHECK BALL	BN1-BJ8	4.00

BEARINGS

OVD-003	FRONT BALL RACE (BRARING)	BN1-BJ8	25.00
OVD-004	REAR BALL RACE (BEARING)	BN1-BJ8	20.00
OVD-005	THRUST BALL RACE (BEARING)	BN1-BJ8	60.00

THRUST WASHERS

OVD-006	UNIDIRECTIONAL CLUTCH	BN1-BJ8	170.00
OVD-007	UNIDIRECTNAL CLUTCH THRUST WASHER	BN1-BJ8	20.00
OVD-008	SUNWHEEL FRONT THRUST WASHER	BN1-BJ8	17.00
OVD-009	SUNWHEEL REAR THRUST WASHER	BN1-BJ8	20.00

ACCUMULATOR HOUSING

OVD-010	ACCUMULATOR HOUSING	BN1-BJ8	90.00
OVD-011	ACCUMULATOR PISTON RING SET	BN1-BJ8	90.00
OVD-012	ACCUMULATOR PISTON	BN1-BJ8	50.00

O RINGS

OVD-017	SOLENOID OPERAT. LEVER O RING	BN1-BJ8	1.10
OVD-018	OPER. PISTON O RING	BN1-BJ8	1.10
OVD-019	ACCUMULATOR O RING	BN1-BJ8	1.65
OVD-020	SPEEDO DRIVE O RING	BN1-BJ8	1.10

OVERDRIVE ELECTRIC

ELE-037	OVERDRIVE THROTTLE	BN1-BJ8	160.00
ELE-078	THROTTLE RELAY ROD	BN1-BJ8	18.00
ELE-010	OVERDRIVE RELAY DECAL	BN1-BJ8	5.50
ELE-038	OVERDRIVE RELAY (PUSH ON TERMINAL)	BN1-BJ8	40.00
ELE-039	OVERDRIVE INHIBITOR SWITCH	BN4-BJ8	14.00
ELE-040	OVERDRIVE SOLENOID	BN1-BJ8	60.00

OVERDRIVE WIRING HARNESS: SEE ELECTRICAL SECTION

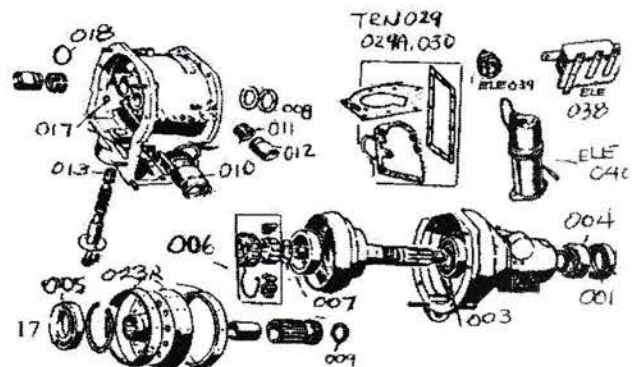

TOP & TONNEAU

Tops & tonneaus are stocked in black only. All made with English everflex material. If you wish to order any other color, please allow 2-4 weeks. There is also a 5% surcharge for red, blue, tan & white s.

TONNEAU

TON-001	TONNEAU	BN1-BN2	350.00
TON-002	TONNEAU	BN6,BN7	350.00
TON-003	TONNEAU	BN4-BT7	500.00
TON-004	TONNEAU	BJ7-BJ8	500.00
TON-009	TONNEAU STIFFENER SET	BN4-BT7	55.00
TON-007	TONNEAU BAR LOCATING PEG SET	LNGBRIDGE	26.00
TON-005	TONNEAU BAR (44") 2 PIECES	LNGBRIDGE	90.00
TON-008	TONNEAU BAR (46") 2 PIECES	BN4-BT7	90.00
TON-006	TONNEAU BAR	BJ7-BJ8	55.00
TON-010	TONNEAU BAR BAG	BJ7-BJ8	50.00

TOP

TOP-001	TOP	BN1-BN2	600.00
TOP-002	TOP	BN6,BN7	600.00
TOP-003A	TOP	LNGBRIDGE	600.00
TOP-003	TOP	BN4,BT7	600.00
TOP-004	TOP	BJ7-BJ8	750.00
TOP-005A	TOP BOOT	BJ7	400.00
TOP-005	TOP BOOT	BJ8	400.00
TOP-024	TOP WEBBING	BJ7-BJ8	11.00
TOP-035	TOP WEBBING CLAMP	BJ7-BJ8	6.00
TOP-009	TOP FRAME-WINDSHIELD SEAL	BN1-BT7	25.00
TOP-010	TOP FRAME-WINDSHIELD SEAL	BJ7-BJ8	35.00
TOP-018	TOP WINDLACING (PER FOOT)	BJ7-BJ8	10.00
TOP-025	TOP WINDLACING END CAP (LH/RH)	BJ7-BJ8	5.00
TOP-015	TOP TO TACKING RAIL CLIP	BJ7-BJ8	0.45

TOP-006A	WOOD BOW	BN1-BN2	50.00
TOP-006	WOOD BOW	BN4-BT7	180.00
TOP-007	WOOD BOW	BJ7-BJ8	200.00
TOP-008A	ALUMINUM BOW	BN6,BN7	150.00
TOP-008	ALUMINUM BOW	BN4,BT7	150.00
TOP-008B	ALUMINUM BOW	BJ7-BJ8	110.00

TOP-011A	TOP LATCHES (PAIR)	BN1-BT2	110.00
TOP-011	TOP LATCHES (PAIR)	BN4-BT7	100.00
TOP-036	TOP LATCHES (PAIR)	BN6,BN7	180.00
TOP-031	TOP LATCHES (PAIR)	BJ7-BJ8	125.00

TOP-012A	TOP LATCHES STUD CURVED WSHR	BN1-BN2	3.00
TOP-012	TOP LATCHES STUD	BN1-BN2	18.00
TOP-013	TOP LATCHES STUD	BN4-BT7	18.00

TOP-014	TOP HOLD DOWN BAR CHROME RETAINER 2 SEATR		10.00
TOP-020	TOP HOLD DOWN BAR:REAR SHROUD	BN1-BN2	35.00
TOP-021	TOP HOLD DOWN BAR:REAR SHROUD	BN6,BN7	35.00

TOP-023	TOP FRAME CHROME TRIANGULAR	BN1-BN2	15.00
TOP-017	TOP FRAME SLIDING TRACK	LNGBRIDGE	35.00
TOP-040	TOP FRAME HOOK BRACKET	LNGBRIDGE	40.00
TOP-032	TOP FRAME SOCKET FINISHR CAP	BN6,BN7	9.00
TOP-028	TOP FRAME FLOOR BOX (LH/RH)	BN6,BN7	55.00
TOP-029	TOP FRAME STRAP	BN6,BN7	35.00

TOP-030	TOP FRAME REAR FINISHING BAR	BJ7-BJ8	35.00
TOP-027	TOP FRAME WINDOW WOOD SET	BJ7-BJ8	300.00
TOP-038	TOP FRAME ALUMINUM BRACKET SET	BJ7-BJ8	2000.00
TOP-019	TOP FRAME SPRING & ARMACORD BOOT	BJ7-BJ8	20.00
TOP-033	TOP FRAME BUFFER & BRKT (LH/RH)	BJ7-BJ8	26.00
TOP-015	CLIP	BJ7-BJ8	0.45
TOP-034	TOP TACKING RAIL	BJ7-BJ8	90.00

TRIM & GRILLS

EMBLEMS

TRM-001	FRONT SHROUD EMBLEM	BN1-BT7	150.00
TRM-001A	MK II FT SHROUD EMB (ENAMEL)	BT7-BJ7	350.00
TRM-002A	MK III FT SHROUD EMB (ENAMEL)	BJ8	350.00

TRM-030	AUSTIN OF ENGLAND	BN1	18.00
TRM-003	AUSTIN HEALEY SCRIPT	BN1-BJ8	20.00
TRM-004	100 FLASH	BN1-BN2	20.00
TRM-005	100-6 FLASH	BN4-BN6	27.00
TRM-006	3000 FLASH	BT7-BJ8	20.00

GRILL

TRM-022	GRILL ASSEMBLY	BN1-BN2	1200.00
TRM-023	GRILL CLAW WASHER	BN1-BN2	7.00
TRM-007	HORIZONTAL GRILL TOP SECT	BN4-BT7	600.00
TRM-015	HORIZONTAL GRILL SLAT SECT	BN4-BT7	650.00
TRM-013	HORIZONTAL GRILL LOWER SECT	BN4-BT7	85.00

TRM-008	VERTICAL GRILL TOP SECT	BN7-BJ8	600.00
TRM-009	VERTICAL GRILL SURROUND	BN7-BJ8	1100.00
TRM-011	VERTICAL GRILL SLAT SECT	BN7-BJ8	450.00
TRM-019	GRILL MOUNTING BRACKET	BT7-BJ8	24.00
TRM-024	GRILL MOUNTING HARDWARE KIT	BT7-BJ8	30.00
TRM-014	BONNET (HOOD) GRILL TOP SECT	BN4-BJ8	75.00
TRM-017	BONNET GRILL LOWER SECTION	HORIZ	75.00
TRM-018	BONNET GRILL LOWER SECTION	VERTI	75.00

MISCELLANEOUS

TRM-020	COCKPIT TRIM CENTER BLOCK	BN4-BT7	10.00
TRM-021	COCKPIT TRIM TAPPED BLOCK	BN4-BT7	6.00

OTHER COCKPIT PIECES ALSO AVAILABLE

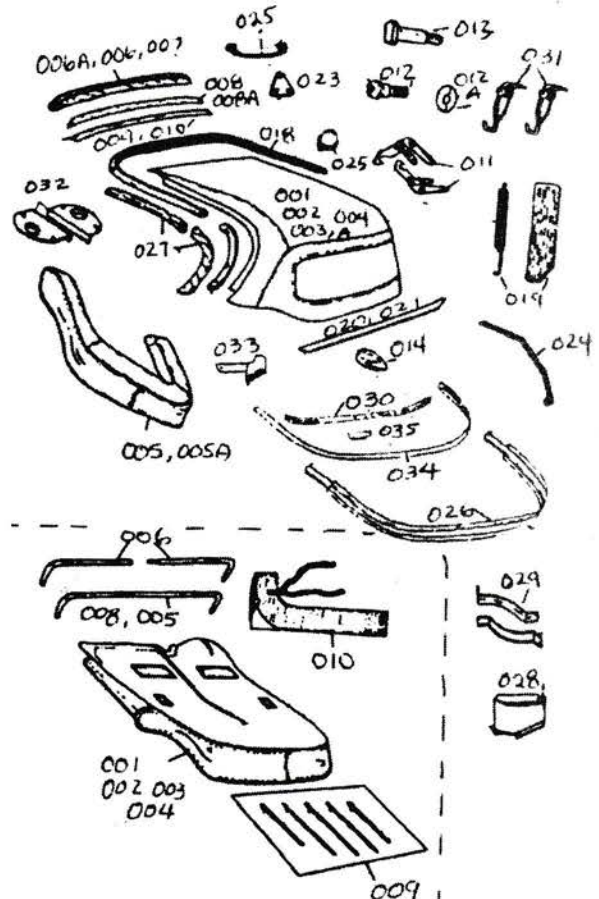

UPHOLSTERY

With the exception of BJ8 kits, all others are custom made to order. Allow 4-6 weeks for delivery. Please specify color, contrasting piping (if desired).

DASH

UPH-004A	DASH TOP SECTION (BLACK)	BN4-BT7	250.00
UPH-004	DASH TOP SECTION (BLACK)	BJ7-BJ8	210.00
UPH-033	DASH TOP WOOD SECTION ONLY	BN4-BT7	100.00
UPH-034	DASH TOP WOOD SECTION ONLY	BJ7-BJ8	120.00
UPH-032	DASH TOP DEMISTER	BN1-BJ8	25.00
UPH-036	UNDER DASH FUZZY STRIP SET	BN4-BJ7	28.00
CHOICE OF COLORS AVAILABLE, \$40.00 PER SET			

PANELS

UPH-005A	FOOTWELL PANEL SET	BN1-BN2	90.00
UPH-005	FOOTWELL PANEL SET	BN4-BJ7	90.00
UPH-006	FOOTWELL PANEL SET	BJ8	90.00
DOR-001	DOOR PANEL SET	BN1-BN2	400.00
DOR-002	DOOR PANEL SET	BN4-BT7	500.00
DOR-003	DOOR PANEL SET	BJ7	300.00
DOR-004	DOOR PANEL SET	BJ8	430.00
DOR-043	ROUND PAD FOR WINDW/ DOOR HANDLES	BJ7-BJ8	3.30
DOR-005	PANEL SCREW & WASHER	BN1-BJ8	0.75
DOR-006	DOOR PANEL CLIP	BJ8	0.75
UPH-022	DOOR TOP ARM REST SET (BLACK)	BJ7-BJ8	160.00

UPH-025	REAR PANEL SET	BN1-BN2	70.00
UPH-026	REAR PANEL SET	BN6-BN7	550.00
UPH-027	REAR PANEL SET	LNGBRIDGE	280.00
UPH-028	REAR PANEL SET	BN4-BT7	350.00
UPH-017	REAR PANEL SET	BJ7	300.00
UPH-007A	REAR PANEL SET (PHASE I)	BJ8	510.00
UPH-007	REAR PANEL SET (PHASE II)	BJ8	510.00

BACKRESTS

UPH-012	BACKREST BRACKET & PEG	BN4,BT7	45.00
UPH-038	BACKREST BRACKET TRACK (PR)	BN4,BT7	45.00
UPH-039	BACKREST BRACKET (LH/RH)	BJ7	35.00
UPH-023	BACKREST WOOD	BN4-BT7	200.00

UPH-046	BACKREST SLIDING BOLT	BJ8	85.00
UPH-011	BACKREST BOLT CHROME BRACKET	BJ8	30.00
UPH-040	BACKREST BOLT OVAL PANEL	BJ8	12.00
UPH-048	BACKREST RECTANGULAR SIDE PLATE	BJ8	9.00
UPH-045	BACKREST TOP LOCATING BRACKET	BJ8	9.00
UPH-041	BACKREST HINGE SET (5 HINGES)	BJ8	150.00
UPH-049	BACKREST FOLD OUT WOOD TRAY	BJ8	590.00

REAR DECK KITS

UPH-016	REAR ARMACORD KIT & SPARE WHL BAG	BN1-BN2	380.00
UPH-037	REAR ARMACORD KIT	BN6-BN7	80.00
UPH-042	BATTERY HATCH STRAP HOLD-DOWN	BN6-BN7	12.00

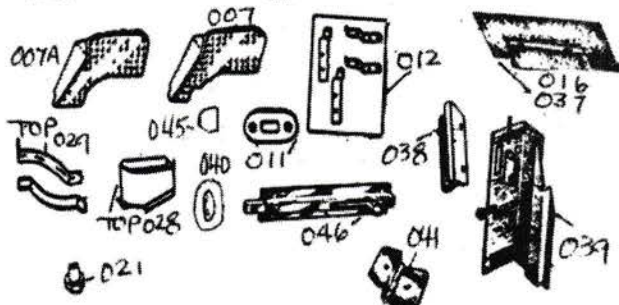
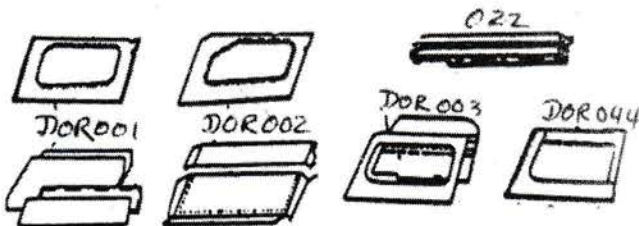
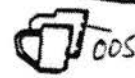
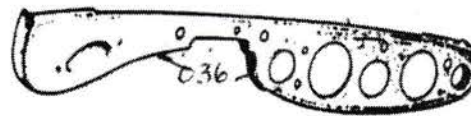
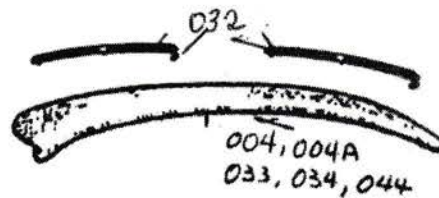
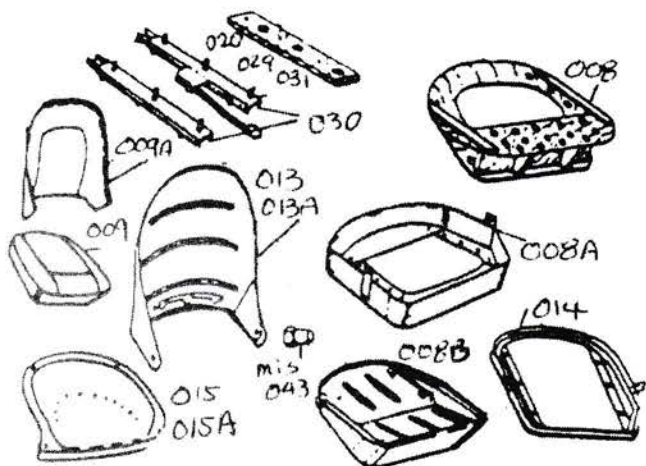

SEATS (all front seat kits include center arm rest)

UPH-002L	FRONT SEAT KIT (LEATHER)	BN1-BJ7	1200.00
UPH-002V	FRONT SEAT KIT (VINYL)	BN1-BJ8	900.00
UPH-002A	ORIGINAL STYLE FRONT SEAT KIT	BJ8	1270.00
UPH-002	FRONT SEAT KIT (LEATHER)	BJ8	1500.00
UPH-003L	REAR SEAT KIT (LEATHER)	BN4-BJ7	610.00
UPH-003V	REAR SEAT KIT (VINYL)	BN4-BJ7	420.00
UPH-003AL	REAR SEAT KIT (LEATHER)	BJ8	1200.00
UPH-003A	ORIGINAL STYLE REAR SEAT KIT	BJ8	1100.00
TOP-015	UPHOLSTERY CLIP	BN4-BJ8	0.45
UPH-009	FOAM SEAT CUSHION (LH/RH)	BN1-BJ7	90.00
UPH-010	FOAM SEAT CUSHION (LH/RH)	BJ8	75.00
UPH-009A	FOAM SEAT BACK	BN1-BJ7	60.00
UPH-010A	FOAM SEAT BACK	BJ8	50.00
UPH-008	WOOD SEAT PAN (LH/RH)	BN1-BN4	110.00
UPH-008A	METAL SEAT PAN (LH/RH)	BN1-BN4	265.00
UPH-013A	METAL SEAT BACK	BN1-BN4	265.00
UPH-008B	SEAT PAN (LH/RH)	BN4-BJ8	265.00
UPH-014	SEAT FRAME - FLOOR (LH/RH)	BN4-BJ8	200.00
UPH-013	SEAT BACK	BN4-BJ8	265.00
UPH-030	SEAT TRACK SET (LH/RH)	BN1-BJ8	110.00
UPH-021	SEAT TRACK NUT SET	BN1-BJ8	15.00
UPH-020	METAL SEAT TRACK SHIM SET	BN1-BJ8	25.00
UPH-031	WOOD SEAT TRACK SHIM SET	BN4-BJ8	20.00
UPH-015	REAR SEAT PAN	BN4-BJ8	200.00

WHEELS/FRONT & REAR AXLES

FRONT HUB BEARINGS

WHL-001A	FRONT WHEEL OUTER BEARING	BN1	35.00
WHL-001B	FRONT WHEEL OUTER BEARING (TIMKEN)	BN2-BJ8	50.00
WHL-001C	FRONT WHEEL OUTER BEARING (TIMKEN)	BJ8*	17.00
WHL-002	FRONT WHEEL INNER BEARING	BN1	60.00
WHL-003	FRONT WHEEL INNER BEARING (TIMKEN)	BN2-BJ8	22.00
WHL-004A	FRONT WHEEL BEARING SHIM	BN2-BJ8	2.75
WHL-004	FRONT WHEEL BEARING SHIM	BJ8*BN1	1.00
shims are available in .003; .005; .010; .030 sizes			
WHL-038	FRONT BEARING SPACER	BN1, BJ8*	18.50
WHL-039	FRONT BEARING SPACER	BN2-BJ8	30.00
WHL-006	FRONT BEARING DUST COVER	BN1-BJ8	25.00
WHL-007	FRONT BEARING DUST COVER	BJ8*	7.00
WHL-051	SWIVEL AXLE BEARING SPACER	BJ8*	50.00

FRONT HUBS

WHL-005	FRONT WHEEL SEAL	BN1-BJ8	5.50
WHL-040	FRONT HUB TAB WASHER	BN1-BJ8	1.75
WHL-053	FRONT HUB CASTLE NUT	BN1-BJ8	5.00
WHL-047	FRONT HUB NUT	BN1	5.00
WHL-015	FRONT HUB STUD	BN1	7.00
WHL-054	FRONT HUB STUD	BN2-BN6	15.00
WHL-055	FRONT HUB STUD	BN7-BJ8	9.00
WHL-008A	FRONT HUB (LH/RH)	BN1	180.00
WHL-008	FRONT HUB (LH/RH)	BN2-BN6	200.00
WHL-009	FRONT HUB: FINE THREAD (LH/RH)	BN7-BJ8	200.00
WHL-010	FRONT HUB: COARSE THREAD (LH/RH)	BJ8*	200.00

REAR HUBS

WHL-024A	REAR HUB: 4 BOLT AXLE (LH/RH)	BN1**	175.00
WHL-024	REAR HUB: FINE THREAD (LH/RH)	BN1-BJ8	110.00
WHL-025	REAR HUB: COARSE THREAD (LH/RH)	BJ8*	110.00
WHL-011A	REAR HUB NUT	BN1**	9.00
WHL-012	REAR HUB NUT	BN1-BJ8	9.00
WHL-013	DISC WHEEL NUT		4.00
WHL-011	REAR HUB STUD	BN1**	10.00
WHL-014	REAR HUB STUD	BN1-BJ8	8.00
WHL-030	REAR WHEEL BEARING HUB	BN2-BJ8	200.00

REAR AXLE

WHL-044A	PINION SEAL	BN1**	10.00
WHL-044	PINION SEAL	BN1-BJ8	7.00
WHL-045	REAR END GASKET	BN1-BJ8	2.20
WHL-034	HALF SHAFT RETAINING SCREW	BN1-BJ8	0.55
WHL-016A	HALF SHAFT AXLE NUT	BN1	27.00
WHL-016	HALF SHAFT AXLE NUT (LH/RH)	BN2-BJ8	20.00
WHL-017A	HALF SHAFT AXLE NUT TAB WASHER	BN1	4.00
WHL-017	HALF SHAFT AXLE NUT TAB WASHER	BN2-BJ8	5.00
WHL-018	HALF SHAFT O RING	BN4-BJ8	2.00
WHL-019A	HALF SHAFT GASKET	BN1**	3.00
WHL-019	HALF SHAFT GASKET	BN2-BJ8	1.10
WHL-020	REAR BEARING SEAL	BN1**	4.00
WHL-021	REAR BEARING SEAL	BN2-BJ8	4.40
WHL-026	REAR AXLE BREATHER	BN1-BJ8	5.00

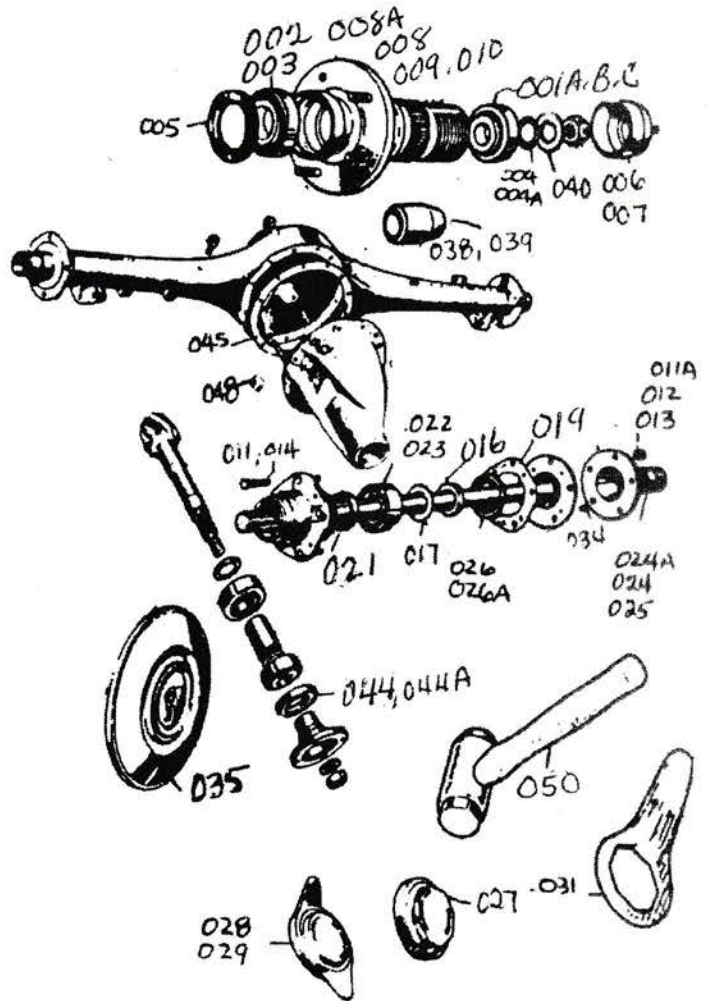

REAR AXLE BEARINGS

WHL-022	REAR WHEEL BEARING	BN1**	50.00
WHL-023	REAR WHEEL BEARING	BN1-BJ8	50.00

WHL-048.....	FRONT PINION BEARING	BN1-BJ8	36.00
WHL-049	REAR PINION BEARING	BN1-BJ8	85.00
WHL-032	CARRIER BEARING	BN1-BJ8	90.00
WHL-052	PINION BEARING SHIMS (AVAILABLE IN .002, .003, .005, .010 & .030 THICKNESSES, PLEASE SPECIFY)	BN1-BJ8	3.00

KNOCK OFFS / HUB CAPS

WHL-028p	WING KNOCKOFF: FINE THREAD (LH/RH)	BN1-BJ8	120.00
WHL-029p	WING KNOCK OFF: COARSE THRD (LH/RH)	BJ8*	120.00
WHL-027	OCTAGON KNOCK OFF (LH/RH)	BJ8*	65.00
WHL-035	DISC WHEEL HUB CAP		80.00

WHL-050	LEAD HAMMER		60.00
WHL-031	OCTAGON WRENCH		12.10

WHEELS

WHL-041PT	48 SPOKE PAINTED WIRE WHEEL		400.00
WHL-041CH	48 SPOKE CHROME WHEEL W/ STAINLESS SPOKES		600.00
WHL-042PT	60 SPOKE PAINTED WIRE WHEEL		400.00
WHL-042CH	60 SPOKE CHROME WHEEL W/ STAINLESS SPOKES		600.00

Let us know in advance if you want to put 60 spoke wheels on cars fitted with brake drums (BN1-BN6), as these must be custom made. There is a surcharge for these wheels.

*PHASE 2 BJ8,
**4 BOLT REAR AXLE



WINDOW & WINDSHIELD

SIDE CURTAINS

WND-011	SIDE CURTAIN (PR) (CHOICE OF COLOR)	BN1-BN2	980.00
WND-017	SIDE CURTAIN SCKET WOOD BLOCK SET	BN1-BN2	22.00
WND-013	SIDE CURTAIN SOCKET	BN1-BN2	9.00
WND-015L	SIDE CURTAIN WING NUT	LNGBRDGE	9.00
WND-016L	SIDE CURTAIN WING NUT PLATE	LNGBRDGE	9.00
WND-011A	SIDE CURTAIN (PAIR)	BN4-BT7	610.00
WND-019A	SIDE CURTAIN PLEXIGLASS SET	LNGBRDGE	70.00
WND-019	SIDE CURTAIN PLEXIGLASS SET	BN4-BT7	70.00
WND-020	SIDE CURTAIN FELT STRIP SET	BN4-BT7	8.00
WND-012	SIDE CURTAIN RUBBER SEAL SET	BN4-BT7	36.00
WND-014	SIDE CURTAIN SOCKET	BN4-BT7	14.00
WND-015	SIDE CURTAIN WING NUT	BN4-BT7	9.00
WND-016	SIDE CURTAIN WING NUT PLATE	BN4-BT7	13.00
WND-024	SIDE CURTAIN BAG (SPECIFY MODEL)		100.00

WINDOWS

WND-001	DOOR GLASS (LH/RH)	BJ7-BJ8	130.00
WND-018	DOOR GLASS METAL FRAME	BJ7-BJ8	70.00
WND-002	WINDOW CRANK	BJ7-BJ8	55.00
WND-003	WINDOW CRANK ESCUTCHEON	BJ7-BJ8	20.00
WND-004	WINDOW CRANK SPRING	BJ7-BJ8	3.00
WND-021	WINDOW CRANK PLASTIC CROWN	BJ7-BJ8	9.00
WND-005	WINDOW GUIDE	BJ7-BJ8	2.85
WND-006	WINDOW FUZZY SEAL	BJ7-BJ8	6.00
WND-006A	WINDOW FUZZY SEAL CLIP	BJ7-BJ8	0.60
WND-007	WINDOW RUBBER SEAL (LH/RH)	BJ7-BJ8	7.00
WND-008	WINDOW RUBBER SEAL CLIP	BJ7-BJ8	1.00
WND-022	WINDOW REGULATOR (LH/RH)	BJ7-BJ8	220.00
WND-023	WINDOW REGULATOR TO FRAME BRKT	BJ7-BJ8	50.00
WND-009	VENT RUBBER TIP (PAIR)	BJ7-BJ8	7.00
WND-010	VENT GASKET (LH/RH)	BJ7-BJ8	30.00

WINDSHIELD

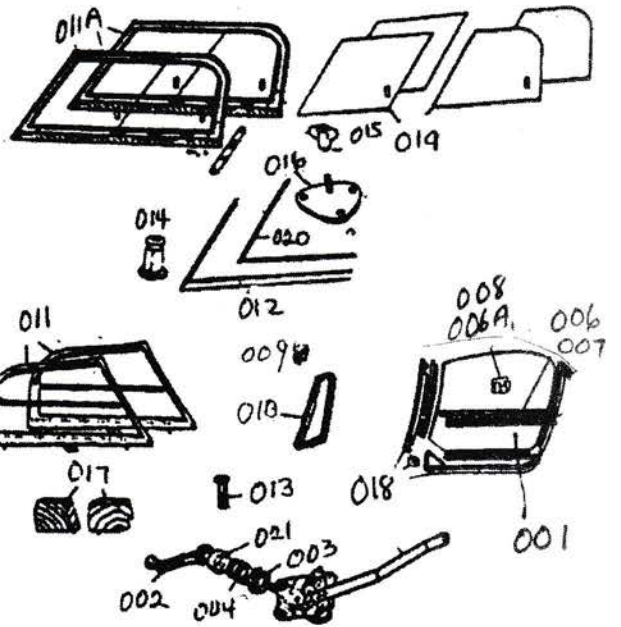
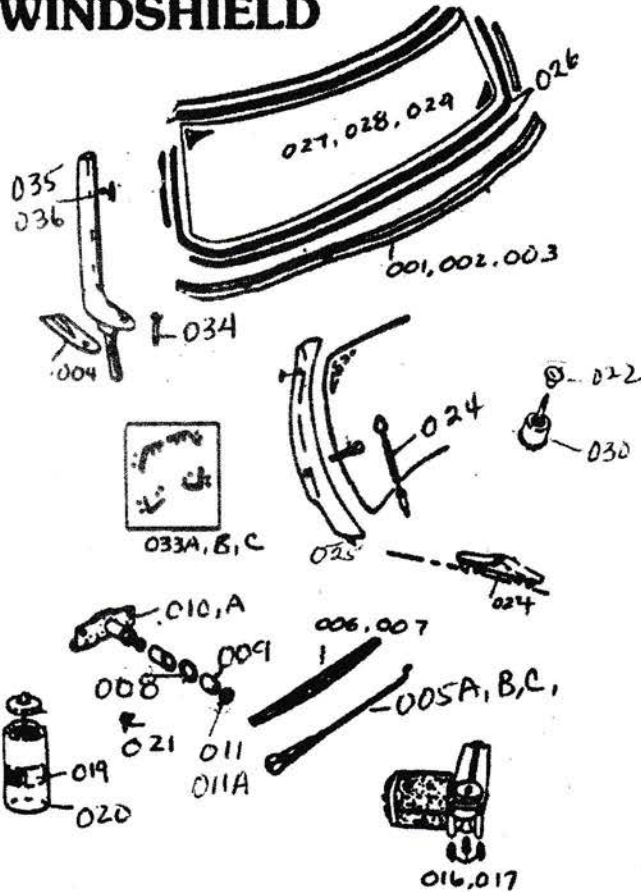

WINDSHIELDS

WNS-001	WINDSHIELD TO BODY GASKET	BN1-BN2	40.00
WNS-002	WINDSHIELD TO BODY GASKET	BN4-BT7	12.00
WNS-003	WINDSHIELD TO BODY GASKET	BJ7-BJ8	20.00
WNS-034	WINDSHIELD POST-BODY SCREW	BN4-BT7	1.50
WNS-004	WINDSHIELD POST-PAD	BN4-BT7	5.00
WNS-035	WINDSHIELD PILLAR SCREW	BN4-BT7	0.83
WNS-036	WINDSHIELD PILLAR SCREW	BJ7-BJ8	1.10
WNS-037	WINDSHIELD PILLAR SHIM	BJ7-BJ8	7.00
WNS-026	WINDSHIELD GLASS PACKING/GLAZING	BJ7-BJ8	38.00

WIPERS

WNS-005A	WIPER ARM	BN1	25.00
WNS-005B	WIPER ARM	BN2-BT7	25.00
WNS-005C	WIPER ARM	BJ7-BJ8	25.00
WNS-006	WIPER BLADE	BN1-BT7	15.00
WNS-007	WIPER BLADE	BJ7-BJ8	12.00
WNS-008	WIPER CHROME COVER GASKET	BN1-BJ8	1.25
WNS-009A	WIPER CHROME COVER	BN1	30.00
WNS-009	WIPER CHROME COVER	BN2-BJ8	5.00
WNS-011A	WIPER CHROME COVER NUT	BN1	7.00
WNS-011	WIPER CHROME COVER NUT	BN2-BJ8	2.00
WNS-010	WIPER WHEEL BOX	BN2-BJ8	50.00
WNS-016	WIPER MTR MOUNT RUB BUSH & BRT (SET)	BN1-BJ8	19.00
WNS-015	WIPER MOTOR BRUSH SET	BN1-BJ8	20.00

WINDSHIELD WASHER

WNS-022	WINDSHIELD WASHER PUMP KNOB	BN4-BJ7	10.00
WNS-032	WINDSHIELD WASHER PUMP CUP ASMBLY	BN4-BJ7	28.00
WNS-030	WINDSHIELD WASHER PUMP ASSEMBLY	BN4-BT7	65.00
WNS-031	WINDSHIELD WASHER PUMP	BJ8	60.00
WNS-021	WINDSHIELD WASHER NOZZLE	BN4-BJ8	6.00
WNS-019	WINDSHIELD BOTTLE "TUDOR" DECAL	BJ8	3.00
WNS-020	WINDSHIELD WASHER BOTTLE	BJ8	19.00

MISCELLANEOUS: 100 FOLD DOWN MECHANISM

WNS-025	WINDSHIELD SWIVEL LINK ARM	BN1-BN2	80.00
WNS-023	WINDSHIELD FOLD DOWN RECEPTACLE	BN1-BN2	65.00
WNS-024	WINDSHIELD SPRING ASSEMBLY	BN1-BN2	25.00
WNS-040	WINDSHIELD KNURLED KNOB & PIN	BN1-BN2	45.00
WNS-041	WINDSHIELD KNOB SCREW	BN1-BN2	25.00